



**JW WINCO**<sup>®</sup>  
A Ganter Company

---

**Highlights**

# Gears and Racks Made of Polyamid



Standard Parts. **Winco.**



# Contents

---

## **Gears and Racks**

General Notes	→ page	2
Technical Instructions	→ page	3
Technical Instructions for Plastic Gears	→ page	5
<hr/>		
Spur Gears EN 7802	→ page	7
Racks EN 7822	→ page	17

The publication of this catalog renders all previous editions invalid. All editions meet the best available technology during printing. We reserve the right to make technical modifications or modifications resulting from an error as well as the right to remove individual items from the product range. The products of this catalog were developed as standard parts with the aim of covering the widest possible spectrum of requirements. We shall not assume any responsibility or liability for special applications with extraordinary requirements on our products. Our design department will gladly answer questions on certain product features, such as missing tolerances, dimensions, and stability. We will deliver based on our terms and conditions of payment and delivery. Download is available at [www.jwwinco.com](http://www.jwwinco.com). J.W. Winco, Inc. has all rights to the catalog. Reproduction, including excerpts, is prohibited.  
J.W. Winco, Inc., February 2023

## Gears

Gears transfer a rotary motion from a driving shaft to a driven shaft via a positive locking. Depending on the ratio of the number of teeth of the gears used, the speed and the torque may be retained, decreased or increased. This is called the gear ratio, where the driven gear is put into relation with the driving gear. The reverse relationship applies to the resulting speeds. See the equations below. Due to the positive locking between the gear pairs, the rotational movement is transmitted precisely and without slippage.

A pairing of two or more combined gears is called a gear train or gearbox. The smallest gear is often referred to as the pinion, while the largest is simply called a gear. The driving and the driven gears always rotate in opposite directions. If this is not desired, a third gear must be positioned between them as an idler gear. Gear trains require only small center distances, which can be influenced by the number of teeth selected.

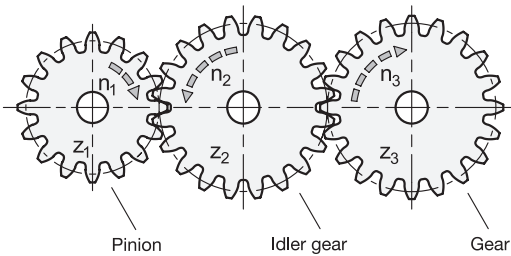

Gear ratio $i =$	
Speed ratio	$i = \frac{n_1}{n_2}$
Tooth count ratio	$i = \frac{z_2}{z_1}$

The tooth shape, size and geometry can be described based on a trapezoidal reference profile, which corresponds in principle to the profile of a rack. The tooth or trapezoid height is standardized with a module value, which is specified in millimeters. The angle of the symmetrical trapezoid sides is referred to as the pressure angle.

The reference profile is mapped onto the individual tooth by rolling over an involute curve along the contact surface. It is only possible to pair gears with the same module and pressure angle.

## Racks

A rack can be considered a segment of a gear with an infinitely large diameter. The teeth of the rack then correspond precisely to the reference profile and have no bent tooth flanks. A combination of a rack and a spur gear allows rotational movements to be converted into linear movements or vice versa. The gear that engages with the rack is called a pinion. Rack drives are used in automation applications with high repeatable precision and frequent changes of direction and load.

Rack drives in which the rack remains stationary while the pinion moves along the rack are frequently used in conveyor systems. The reverse case, in which the pinion rotates around a fixed axis while the rack moves, is often used in extrusion systems as well as lifting and forward feed applications.

The most important mechanical value for the toothed racks is the maximum force that can be exerted on an individual tooth.

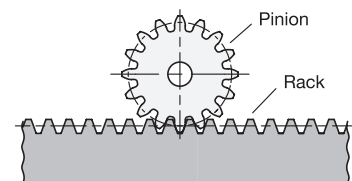

## Gear calculation

The following are the generally applicable formulas for the design of spur gears.

### Formulas

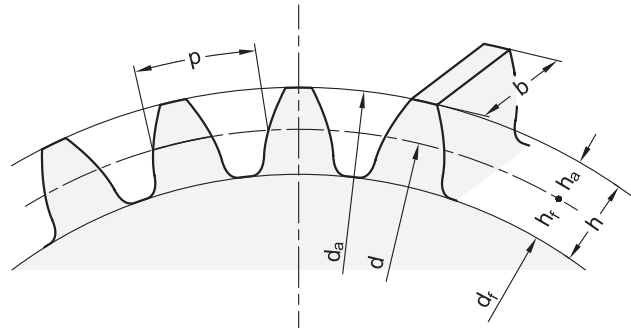

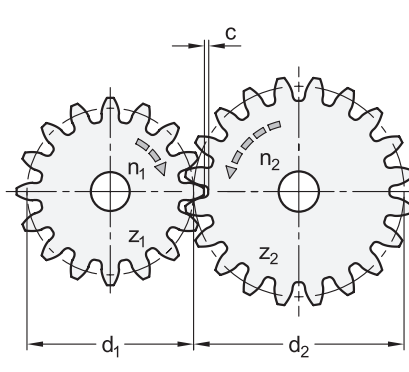
Module <b>m</b> in mm	$m = \frac{p}{\pi}$	Pitch <b>p</b> in mm	$p = \pi \cdot m$
Tooth count <b>z</b>	$z = \frac{d}{m} = \frac{d_a - 2 \cdot m}{m}$	Tooth height <b>h</b> in mm	$h = 2 \cdot m + c$
Pitch circle Ø <b>d</b> in mm	$d = m \cdot z$	Addendum <b>h<sub>a</sub></b> in mm	$h_a = m$
Addendum circle Ø <b>d<sub>a</sub></b> in mm	$d_a = d + 2 \cdot m = m \cdot (z + 2)$	Dedendum <b>h<sub>f</sub></b> in mm	$h_f = m + c$
Root circle Ø <b>d<sub>f</sub></b> in mm	$d_f = d - 2 \cdot (m + c)$	Crest clearance <b>c</b> in mm	$c = 0,1 \cdot m \dots 0,3 \cdot m$
		Gear ratio <b>i</b>	$i = \frac{z_2}{z_1} = \frac{n_1}{n_2}$
		Reference center distance <b>a<sub>d</sub></b> in mm	$a_d = \frac{d_1 + d_2}{2} = \frac{m \cdot (z_1 + z_2)}{2}$
		Center distance <b>a</b> in mm	$a = \frac{d_1 + d_2}{2} + t$
		The following tolerances <b>t</b> must be taken into account for the center distance <b>a</b> : $t = +0.03 / +0.1$ with module 0.5 / 1 / 1.5 $t = +0.08 / +0.3$ with module 2 / 2.5 / 3	

## Tooth profile

The spur gears EN 7802 have involute toothings with a pressure angle of 20°. Only gears with the same module and pressure angle can be paired with each other.

The following relationship applies to the involute toothings:

### Involute Toothings

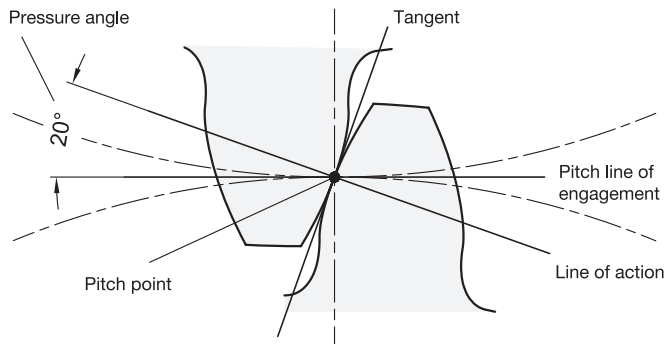

The tooth flanks of the gears are shaped as involutes.

The tangent that is perpendicular to the line of action runs through the contact point between the two tooth flanks (involute). The line of action is at a 20° angle to the pitch line of engagement.

The pitch point is located on the line of engagement at the intersection between the line of action and the center line of the gear axes.

For each gear, a counter gear with an infinitely large pitch diameter can be designed, which has a trapezoidal tooth profile. This reference profile then corresponds precisely to the profile of the rack.

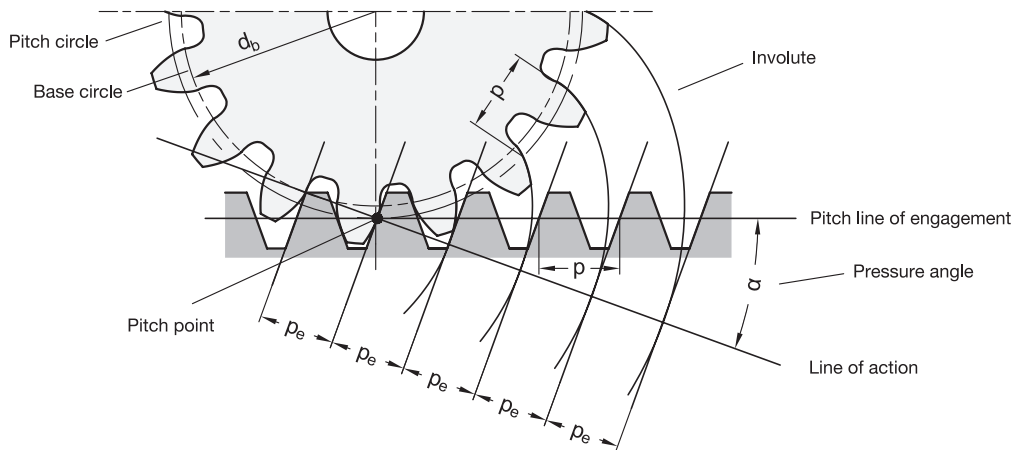

Base circle diameter $d_b$	$d_b = d \cdot \cos \alpha = z \cdot m \cdot \cos \alpha$	<p>The pitch <math>p</math> on the pitch circle corresponds to the pitch <math>p</math> on the line of engagement.</p> <p>The base pitch <math>p_b</math> corresponds to the contact pitch <math>p_e</math>.</p> <p>The contact pitch <math>p_e</math> is determined by the pitch <math>p</math> and the size of the pressure angle <math>\alpha</math>.</p>
Base pitch $p_b$	$p_b = \frac{d_b \cdot \pi}{z} = p \cdot \cos \alpha$	
Contact pitch $p_e$	$p_e \triangleq p_b = p \cdot \cos \alpha = \pi \cdot m \cdot \cos \alpha$	

---

## Material specific advantages

The gears EN 7802 are made of polyamide and offer the following material specific advantages:

- Weight reduction compared with metal gears
- Noise reduction
- Low coefficient of friction, meaning that lubrication is not absolutely required
- High corrosion resistance
- Higher torque transmission compared with other plastics, such as polyacetal (POM) / polyketone (PK)
- Household appliances

In addition, gears of steel are frequently overdimensioned for their application. In such cases, polyamide gears are a cost-effective alternative. The spur gears EN 7802 of polyamide are frequently used in the following applications:

- Packaging and conveyor machines
- Industrial cleaning machines
- Glass and ceramic processing machines
- Agricultural machinery
- Chemical and pharmaceutical industry
- Household appliances

---

## Lubrication / maintenance

One of the main advantages of the spur gears EN 7802 of plastic is the possibility of using them without lubrication. If lubrication is still required to decrease friction and wear or to increase the lifespan of the gear, lithium-saponified grease with a mineral oil base is recommended.

---

## Gear pairing - metal and plastic

The spur gears EN 7802 of plastic can also be used in combination with metal gears.

With this pairing, the smallest gear (pinion) should be of metal and the larger gear of plastic since the wear on the larger gear is distributed over more teeth, resulting in a longer lifespan.

The combination of metal and plastic gears offers additional advantages since metal has a higher thermal conductivity, leading to better heat dissipation during operation and an associated decrease in wear on the plastic gear.

---

## Hub machining of plastic gears

The following points must be observed when making a bore or keyway:

- The clamping jaws used must be precisely matched to the addendum circle of the gear.
- The clamping surface must be as wide as possible. For module 3, for example, it is necessary to clamp at least 3 - 4 teeth and for module 1 at least 7 teeth.
- Cutting parameters and forward feed rates suitable for polyamide must be selected based on the machining method. Cooling or lubrication must be used during machining, if necessary.

## Torque

The torque specifications in the table of the respective standard sheet have been determined through a combination of theoretical calculations and laboratory tests. The empirically determined data has been verified with suitable software, taking into account the VDI 2736 guideline for the design of thermo-plastic gears.

The test series were carried out in continuous operation at a speed of 100-150 rpm without lubrication in order to test the most severe conditions.

The following assumptions were used for the theoretical calculation:

- The tooth force  $F$  is decomposed into the tangential force  $F_t$  and radial force  $F_r$ .
- The radial force  $F_r$  is considered negligible. As a result, the tooth force  $F$  can be simply assumed to have the same value as the tangential force  $F_t$  on the pitch circle.
- The least favorable case is assumed, in which only one tooth is engaged.

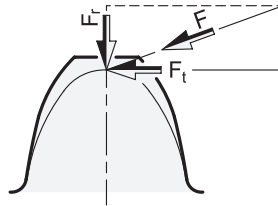

The tangential force  $F_t$  is then correlated with the torque via the pitch circle diameter. The following formula applies to the nominal torque:

$$M = F_t \cdot \frac{d}{2}$$

The torques given in the standard sheet should be considered guide values and may vary based on the specific application situation. Operating conditions such as speed, temperature, pairing of gears of different materials, lubricated or dry operation, etc. have a major influence on the load capacity.



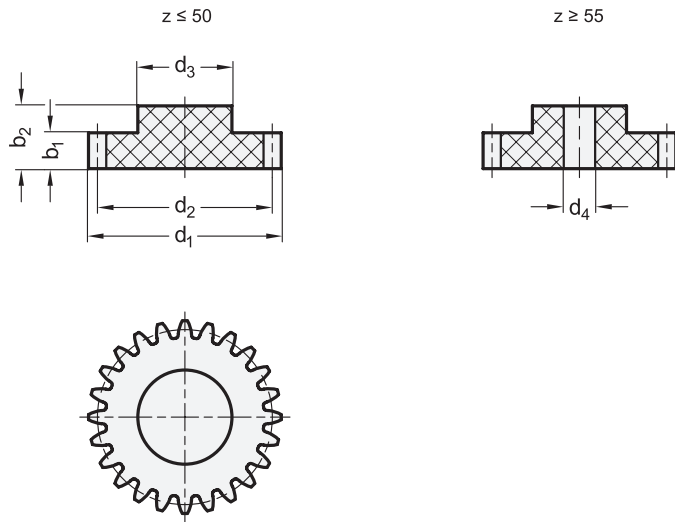

Dimensions in: millimeters - inches

Module	z Tooth count	b <sub>1</sub> Tooth width	b <sub>2</sub>	d <sub>1</sub>	d <sub>2</sub> Pitch circle Ø	d <sub>3</sub>	d <sub>4</sub> Pre-bored hole	Max. torque in Nm
0.5	24	8 0.31	16 0.63	13 0.51	12 0.47	10 0.39	-	0.7
0.5	25	8 0.31	16 0.63	13.5 0.53	12.5 0.49	10 0.39	-	0.7
0.5	30	8 0.31	16 0.63	16 0.63	15 0.59	10 0.39	-	0.8
0.5	32	8 0.31	16 0.63	17 0.67	16 0.63	10 0.39	-	0.9
0.5	36	8 0.31	16 0.63	19 0.75	18 0.71	10 0.39	-	1
0.5	40	8 0.31	16 0.63	21 0.83	20 0.79	10 0.39	-	1.1
0.5	45	8 0.31	16 0.63	23.5 0.93	22.5 0.89	10 0.39	-	1.2
0.5	48	8 0.31	16 0.63	25 0.98	24 0.94	10 0.39	-	1.3
0.5	50	8 0.31	16 0.63	26 1.02	25 0.98	10 0.39	-	1.4
0.5	55	8 0.31	16 0.63	28.5 1.12	27.5 1.08	20 0.79	4 0.16	1.5
0.5	60	8 0.31	16 0.63	31 1.22	30 1.18	20 0.79	4 0.16	1.6
0.5	70	8 0.31	16 0.63	36 1.42	35 1.38	20 0.79	4 0.16	1.9
0.5	80	8 0.31	16 0.63	41 1.61	40 1.57	20 0.79	4 0.16	2.2

**Specification**

- Plastic  
Technopolymer (Polyamide PA)  
- Glass fiber reinforced  
- Temperature resistant up to 248 °F (120 °C)  
- Gray ● GR
- ISO Fundamental Tolerances  
→ Standard Parts Handbook page 2129
- Plastic Characteristics  
→ Standard Parts Handbook page 2135
- RoHS compliant

**On request**

- With keyway
- With bore H9

**Information**

Spur gears EN 7802 of plastic reduce both weight and noise while offering high corrosion resistance. Spur gears of polyamide allow the transmission of significantly higher torques compared with gears made of other plastics. This makes them especially suited for applications with high torques at low speeds. The spur gears have involute toothing with a pressure angle of 20°. Further design details can be found in the technical information.

see also...

- General Notes for Gears → page 2
- Technical Instructions for Gears → page 3

<p>How to order</p> <p><b>EN 7802-0.5-30-GR</b></p>	1	Module
	2	Tooth count z
	3	Color

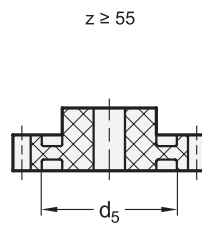
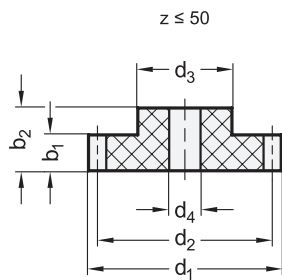

Application example

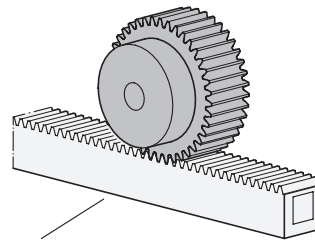
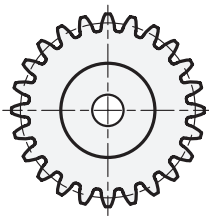

Gear rack EN 7822



Dimensions in: millimeters - inches

Module	z Tooth count		b <sub>1</sub> Tooth width	b <sub>2</sub>	d <sub>1</sub>	d <sub>2</sub> Pitch circle Ø	d <sub>3</sub>	d <sub>4</sub> Pre-bored hole	d <sub>5</sub>	Max. torque in Nm
	GR	VDB								
1	12	12	15 0.59	25 0.98	14 0.55	12 0.47	9 0.35	4 0.16	-	2.5
1	14	-	15 0.59	25 0.98	16 0.63	14 0.55	10 0.39	4 0.16	-	2.9
1	15	15	15 0.59	25 0.98	17 0.67	15 0.59	10 0.39	4 0.16	-	3.1
1	16	16	15 0.59	25 0.98	18 0.71	16 0.63	13 0.51	5 0.20	-	3.3
1	18	-	15 0.59	25 0.98	20 0.79	18 0.71	14 0.55	5 0.20	-	3.7
1	20	20	15 0.59	25 0.98	22 0.87	20 0.79	16 0.63	5 0.20	-	4.1
1	21	-	15 0.59	25 0.98	23 0.91	21 0.83	16 0.63	5 0.20	-	4.3
1	22	-	15 0.59	25 0.98	24 0.94	22 0.87	18 0.71	5 0.20	-	4.5
1	24	24	15 0.59	25 0.98	26 1.02	24 0.94	20 0.79	6 0.24	-	4.9
1	25	-	15 0.59	25 0.98	27 1.06	25 0.98	20 0.79	6 0.24	-	5.1
1	26	-	15 0.59	25 0.98	28 1.10	26 1.02	22 0.87	6 0.24	-	5.3
1	27	-	15 0.59	25 0.98	29 1.14	27 1.06	22 0.87	6 0.24	-	5.5
1	28	-	15 0.59	25 0.98	30 1.18	28 1.10	22 0.87	6 0.24	-	5.7
1	30	30	15 0.59	25 0.98	32 1.26	30 1.18	25 0.98	6 0.24	-	6.1
1	32	32	15 0.59	25 0.98	34 1.34	32 1.26	25 0.98	6 0.24	-	6.6
1	33	-	15 0.59	25 0.98	35 1.38	33 1.30	25 0.98	6 0.24	-	6.8
1	34	-	15 0.59	25 0.98	36 1.42	34 1.34	30 1.18	8 0.31	-	7.0
1	35	-	15 0.59	25 0.98	37 1.46	35 1.38	30 1.18	8 0.31	-	7.2

Dimensions in: millimeters - inches

Module	z Tooth count		b <sub>1</sub> Tooth width	b <sub>2</sub>	d <sub>1</sub>	d <sub>2</sub> Pitch circle Ø	d <sub>3</sub>	d <sub>4</sub> Pre-bored hole	d <sub>5</sub>	Max. torque in Nm
	GR	VDB								
1	36	36	15 0.59	25 0.98	38 1.50	36 1.42	30 1.18	8 0.31	-	7.4
1	38	-	15 0.59	25 0.98	40 1.57	38 1.50	30 1.18	8 0.31	-	7.8
1	39	-	15 0.59	25 0.98	41 1.61	39 1.54	30 1.18	8 0.31	-	8.0
1	40	40	15 0.59	25 0.98	42 1.65	40 1.57	30 1.18	8 0.31	-	8.2
1	42	-	15 0.59	25 0.98	44 1.73	42 1.65	35 1.38	10 0.39	-	8.6
1	44	-	15 0.59	25 0.98	46 1.81	44 1.73	35 1.38	10 0.39	-	9
1	45	45	15 0.59	25 0.98	47 1.85	45 1.77	35 1.38	10 0.39	-	9.2
1	48	48	15 0.59	25 0.98	50 1.97	48 1.89	35 1.38	10 0.39	-	9.8
1	50	-	15 0.59	25 0.98	52 2.05	50 1.97	35 1.38	10 0.39	-	10.2
1	55	-	15 0.59	25 0.98	57 2.24	55 2.17	35 1.38	14 0.55	44 1.73	11.3
1	58	-	15 0.59	25 0.98	60 2.36	58 2.28	35 1.38	14 0.55	44 1.73	11.9
1	60	60	15 0.59	25 0.98	62 2.44	60 2.36	40 1.57	14 0.55	51 2.01	12.3
1	65	-	15 0.59	25 0.98	67 2.64	65 2.56	40 1.57	20 0.79	51 2.01	13.3
1	70	-	15 0.59	25 0.98	72 2.83	70 2.76	40 1.57	20 0.79	61 2.40	14.3
1	72	-	15 0.59	25 0.98	74 2.91	72 2.83	40 1.57	20 0.79	61 2.40	14.7
1	74	-	15 0.59	25 0.98	76 2.99	74 2.91	40 1.57	20 0.79	61 2.40	15.2
1	75	-	15 0.59	25 0.98	77 3.03	75 2.95	50 1.97	20 0.79	66 2.60	15.4
1	77	-	15 0.59	25 0.98	79 3.11	77 3.03	50 1.97	20 0.79	66 2.60	15.8
1	80	-	15 0.59	25 0.98	82 3.23	80 3.15	50 1.97	20 0.79	66 2.60	16.4

### Specification

- Plastic  
Technopolymer (Polyamide PA)  
- Glass fiber reinforced  
- Temperature resistant up to 248 °F (120 °C)  
- Gray  GR
- Plastic  
Technopolymer (Polyamide PA)  
- Glass fiber reinforced  
- Temperature resistant up to 248 °F (120 °C)  
- FDA compliant plastic granulate  
- Blue, RAL 5005, matte finish  
- Visually detectable  VDB
- ISO Fundamental Tolerances  
→ Standard Parts Handbook page 2129
- Plastic Characteristics  
→ Standard Parts Handbook page 2135
- RoHS compliant

### On request

- With keyway
- With bore H9

### Information

- Spur gears EN 7802 of plastic reduce both weight and noise while offering high corrosion resistance.
- Spur gears of polyamide allow the transmission of significantly higher torques compared with gears made of other plastics. This makes them especially suited for applications with high torques at low speeds.
- The spur gears have involute toothing with a pressure angle of 20°. Further design details can be found in the technical information.
- see also...
- General Notes for Gears → page 2
  - Technical Instructions for Gears → page 3
  - Product Family Standard Parts made of Detectable Plastics → Standard Parts Handbook page 2134
  - Gear Racks EN 7822 → page 17

How to order	<b>1</b>	Module
	<b>2</b>	Tooth count z
	<b>3</b>	Color

**EN 7802-1-30-GR**

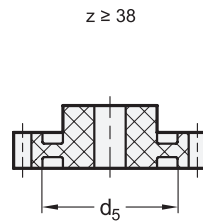
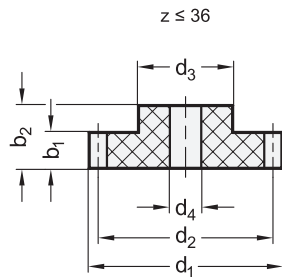

Application example

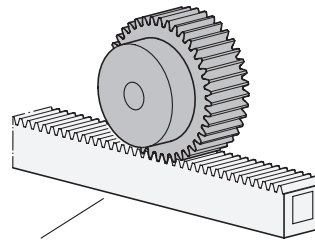
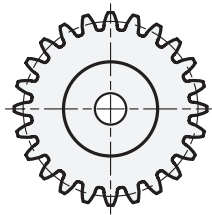

Gear rack EN 7822





Dimensions in: millimeters - inches

Module	z Tooth count		b <sub>1</sub> Tooth width	b <sub>2</sub>	d <sub>1</sub>	d <sub>2</sub> Pitch circle Ø	d <sub>3</sub>	d <sub>4</sub> Pre-bored hole	d <sub>5</sub>	Max. torque in Nm
	GR	VDB								
1.5	12	12	17 0.67	30 1.18	21 0.83	18 0.71	14 0.55	5 0.20	-	6.8
1.5	14	-	17 0.67	30 1.18	24 0.94	21 0.83	16 0.63	5 0.20	-	8
1.5	15	15	17 0.67	30 1.18	25.5 1.00	22.5 0.89	18 0.71	5 0.20	-	8.5
1.5	16	-	17 0.67	30 1.18	27 1.06	24 0.94	18 0.71	5 0.20	-	9.1
1.5	18	18	17 0.67	30 1.18	30 1.18	27 1.06	20 0.79	6 0.24	-	10.3
1.5	20	20	17 0.67	30 1.18	33 1.30	30 1.18	25 0.98	8 0.31	-	11.4
1.5	21	-	17 0.67	30 1.18	34.5 1.36	31.5 1.24	25 0.98	8 0.31	-	12
1.5	22	-	17 0.67	30 1.18	36 1.42	33 1.30	28 1.10	8 0.31	-	12.5
1.5	24	24	17 0.67	30 1.18	39 1.54	36 1.42	28 1.10	8 0.31	-	13.7
1.5	25	-	17 0.67	30 1.18	40.5 1.59	37.5 1.48	30 1.18	8 0.31	-	14.2
1.5	26	-	17 0.67	30 1.18	42 1.65	39 1.54	30 1.18	8 0.31	-	14.8
1.5	28	-	17 0.67	30 1.18	45 1.77	42 1.65	30 1.18	8 0.31	-	16
1.5	30	30	17 0.67	30 1.18	48 1.89	45 1.77	35 1.38	12 0.47	-	17.1
1.5	32	-	17 0.67	30 1.18	51 2.01	48 1.89	35 1.38	12 0.47	-	18.2
1.5	33	-	17 0.67	30 1.18	52.5 2.07	49.5 1.95	35 1.38	12 0.47	-	18.8
1.5	34	-	17 0.67	30 1.18	54 2.13	51 2.01	35 1.38	12 0.47	-	19.4
1.5	35	-	17 0.67	30 1.18	55.5 2.19	52.5 2.07	35 1.38	12 0.47	-	19.9
1.5	36	36	17 0.67	30 1.18	57 2.24	54 2.13	35 1.38	12 0.47	-	20.5

Dimensions in: millimeters - inches

Module	z Tooth count		b <sub>1</sub> Tooth width	b <sub>2</sub>	d <sub>1</sub>	d <sub>2</sub> Pitch circle Ø	d <sub>3</sub>	d <sub>4</sub> Pre-bored hole	d <sub>5</sub>	Max. torque in Nm
	GR	VDB								
1.5	38	-	17 0.67	30 1.18	60 2.36	57 2.24	35 1.38	16 0.63	42 1.65	21.7
1.5	39	-	17 0.67	30 1.18	61.5 2.42	58.5 2.30	35 1.38	16 0.63	42 1.65	22.2
1.5	40	40	17 0.67	30 1.18	63 2.48	60 2.36	40 1.57	16 0.63	48 1.89	22.8
1.5	42	-	17 0.67	30 1.18	66 2.60	63 2.48	45 1.77	16 0.63	53 2.09	23.9
1.5	44	-	17 0.67	30 1.18	69 2.72	66 2.60	45 1.77	16 0.63	53 2.09	25.1
1.5	45	-	17 0.67	30 1.18	70.5 2.78	67.5 2.66	45 1.77	16 0.63	53 2.09	25.6
1.5	46	-	17 0.67	30 1.18	72 2.83	69 2.72	45 1.77	16 0.63	53 2.09	26.2
1.5	48	48	17 0.67	30 1.18	75 2.95	72 2.83	45 1.77	16 0.63	53 2.09	27.4
1.5	50	-	17 0.67	30 1.18	78 3.07	75 2.95	45 1.77	16 0.63	53 2.09	28.5
1.5	51	-	17 0.67	30 1.18	79.5 3.13	76.5 3.01	50 1.97	20 0.79	63 2.48	29.1
1.5	52	-	17 0.67	30 1.18	81 3.19	78 3.07	50 1.97	20 0.79	63 2.48	29.6
1.5	54	-	17 0.67	30 1.18	84 3.31	81 3.19	50 1.97	20 0.79	63 2.48	30.8
1.5	55	-	17 0.67	30 1.18	85.5 3.37	82.5 3.25	50 1.97	20 0.79	63 2.48	31.3
1.5	60	-	17 0.67	30 1.18	93 3.66	90 3.54	55 2.17	20 0.79	73 2.87	34.2
1.5	65	-	17 0.67	30 1.18	100.5 3.96	97.5 3.84	60 2.36	20 0.79	81 3.19	37
1.5	70	-	17 0.67	30 1.18	108 4.25	105 4.13	60 2.36	20 0.79	93 3.66	39.9
1.5	75	-	17 0.67	30 1.18	115.5 4.55	112.5 4.43	60 2.36	20 0.79	93 3.66	42.7
1.5	80	-	17 0.67	30 1.18	123 4.84	120 4.72	60 2.36	20 0.79	109 4.29	45.6

**Specification**

- Plastic  
Technopolymer (Polyamide PA)  
- Glass fiber reinforced  
- Temperature resistant up to 248 °F (120 °C)  
- Gray 
- Plastic  
Technopolymer (Polyamide PA)  
- Glass fiber reinforced  
- Temperature resistant up to 248 °F (120 °C)  
- FDA compliant plastic granulate  
- Blue, RAL 5005, matte finish  
- Visually detectable 
- ISO Fundamental Tolerances  
→ Standard Parts Handbook page 2129
- Plastic Characteristics  
→ Standard Parts Handbook page 2135
- RoHS compliant

**On request**

- With keyway
- With bore H9

**Information**

Spur gears EN 7802 of plastic reduce both weight and noise while offering high corrosion resistance. Spur gears of polyamide allow the transmission of significantly higher torques compared with gears made of other plastics. This makes them especially suited for applications with high torques at low speeds.

The spur gears have involute toothing with a pressure angle of 20°. Further design details can be found in the technical information.

see also...

- General Notes for Gears → page 2
- Technical Instructions for Gears → page 3
- Product Family Standard Parts made of Detectable Plastics → page 2134
- Gear Racks EN 7822 → page 17

How to order	  	1 Module
		2 Tooth count z
		3 Color

**EN 7802-1.5-48-VDB**

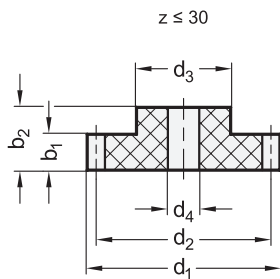

$z \geq 31$

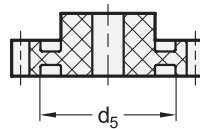

Application example

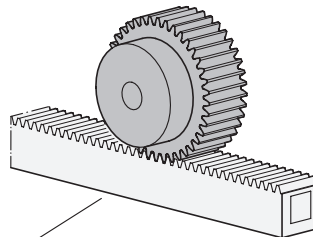
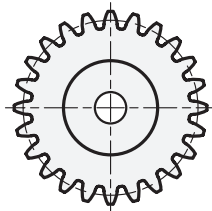

Gear rack EN 7822



Dimensions in: millimeters - inches

Module	z Tooth count	GR	VDB	b <sub>1</sub> Tooth width	b <sub>2</sub>	d <sub>1</sub>	d <sub>2</sub> Pitch circle Ø	d <sub>3</sub>	d <sub>4</sub> Pre-bored hole	d <sub>5</sub>	Max. torque in Nm
2	12	12	12	20 0.79	35 1.38	28 1.10	24 0.94	18 0.71	8 0.31	-	15.5
2	13	-	-	20 0.79	35 1.38	30 1.18	26 1.02	18 0.71	8 0.31	-	16.8
2	14	-	-	20 0.79	35 1.38	32 1.26	28 1.10	20 0.79	8 0.31	-	18.1
2	15	15	15	20 0.79	35 1.38	34 1.34	30 1.18	22 0.87	8 0.31	-	19.4
2	16	-	-	20 0.79	35 1.38	36 1.42	32 1.26	25 0.98	8 0.31	-	20.7
2	17	-	-	20 0.79	35 1.38	38 1.50	34 1.34	25 0.98	8 0.31	-	21.9
2	18	-	-	20 0.79	35 1.38	40 1.57	36 1.42	30 1.18	10 0.39	-	23.2
2	19	-	-	20 0.79	35 1.38	42 1.65	38 1.50	30 1.18	10 0.39	-	24.5
2	20	20	20	20 0.79	35 1.38	44 1.73	40 1.57	30 1.18	10 0.39	-	25.8
2	21	-	-	20 0.79	35 1.38	46 1.81	42 1.65	30 1.18	10 0.39	-	27.1
2	22	-	-	20 0.79	35 1.38	48 1.89	44 1.73	30 1.18	10 0.39	-	28.4
2	23	-	-	20 0.79	35 1.38	50 1.97	46 1.81	35 1.38	10 0.39	-	29.7
2	24	24	24	20 0.79	35 1.38	52 2.05	48 1.89	35 1.38	10 0.39	-	31
2	25	-	-	20 0.79	35 1.38	54 2.13	50 1.97	35 1.38	10 0.39	-	32.3
2	26	-	-	20 0.79	35 1.38	56 2.20	52 2.05	40 1.57	14 0.55	-	33.6
2	27	-	-	20 0.79	35 1.38	58 2.28	54 2.13	40 1.57	14 0.55	-	34.9
2	28	-	-	20 0.79	35 1.38	60 2.36	56 2.20	40 1.57	14 0.55	-	36.1
2	29	-	-	20 0.79	35 1.38	62 2.44	58 2.28	40 1.57	14 0.55	-	37.4
2	30	30	30	20 0.79	35 1.38	64 2.52	60 2.36	40 1.57	14 0.55	-	38.7
2	31	-	-	20 0.79	35 1.38	66 2.60	62 2.44	40 1.57	14 0.55	48 1.89	40
2	32	-	-	20 0.79	35 1.38	68 2.68	64 2.52	45 1.77	16 0.63	51 2.01	41.3

Dimensions in: millimeters - inches

Module	z Tooth count		b <sub>1</sub> Tooth width	b <sub>2</sub>	d <sub>1</sub>	d <sub>2</sub> Pitch circle Ø	d <sub>3</sub>	d <sub>4</sub> Pre-bored hole	d <sub>5</sub>	Max. torque in Nm
	GR	VDB								
2	33	-	20 0.79	35 1.38	70 2.76	66 2.60	45 1.77	16 0.63	51 2.01	42.6
2	34	-	20 0.79	35 1.38	72 2.83	68 2.68	45 1.77	16 0.63	51 2.01	43.9
2	35	-	20 0.79	35 1.38	74 2.91	70 2.76	45 1.77	16 0.63	51 2.01	45.2
2	36	36	20 0.79	35 1.38	76 2.99	72 2.83	50 1.97	16 0.63	59 2.32	46.5
2	37	-	20 0.79	35 1.38	78 3.07	74 2.91	50 1.97	16 0.63	59 2.32	47.8
2	38	-	20 0.79	35 1.38	80 3.15	76 2.99	50 1.97	16 0.63	59 2.32	49.1
2	39	-	20 0.79	35 1.38	82 3.23	78 3.07	50 1.97	16 0.63	59 2.32	50.4
2	40	40	20 0.79	35 1.38	84 3.31	80 3.15	55 2.17	16 0.63	66 2.60	51.6
2	42	-	20 0.79	35 1.38	88 3.46	84 3.31	55 2.17	16 0.63	66 2.60	54.2
2	44	-	20 0.79	35 1.38	92 3.62	88 3.46	60 2.36	16 0.63	68 2.68	56.8
2	45	-	20 0.79	35 1.38	94 3.70	90 3.54	60 2.36	16 0.63	68 2.68	58.1
2	46	-	20 0.79	35 1.38	96 3.78	92 3.62	60 2.36	16 0.63	75 2.95	59.4
2	48	48	20 0.79	35 1.38	100 3.94	96 3.78	60 2.36	16 0.63	75 2.95	62
2	50	-	20 0.79	35 1.38	104 4.09	100 3.94	60 2.36	20 0.79	84 3.31	64.6
2	52	-	20 0.79	35 1.38	108 4.25	104 4.09	60 2.36	20 0.79	90 3.54	67.1
2	54	-	20 0.79	35 1.38	112 4.41	108 4.25	60 2.36	20 0.79	90 3.54	69.7
2	57	-	20 0.79	35 1.38	118 4.65	114 4.49	60 2.36	20 0.79	90 3.54	73.6
2	60	-	20 0.79	35 1.38	124 4.88	120 4.72	60 2.36	20 0.79	101 3.98	77.5
2	62	-	20 0.79	35 1.38	128 5.04	124 4.88	60 2.36	20 0.79	101 3.98	80
2	64	-	20 0.79	35 1.38	132 5.20	128 5.04	60 2.36	20 0.79	101 3.98	82.6
2	65	-	20 0.79	35 1.38	134 5.28	130 5.12	60 2.36	20 0.79	101 3.98	83.9
2	66	-	20 0.79	35 1.38	136 5.35	132 5.20	60 2.36	20 0.79	101 3.98	85.2
2	68	-	20 0.79	35 1.38	140 5.51	136 5.35	60 2.36	20 0.79	101 3.98	87.8
2	70	-	20 0.79	35 1.38	144 5.67	140 5.51	60 2.36	20 0.79	117 4.61	90.4
2	72	-	20 0.79	35 1.38	148 5.83	144 5.67	60 2.36	20 0.79	117 4.61	93
2	74	-	20 0.79	35 1.38	152 5.98	148 5.83	60 2.36	20 0.79	117 4.61	95.5
2	75	-	20 0.79	35 1.38	154 6.06	150 5.91	60 2.36	20 0.79	117 4.61	96.8
2	76	-	20 0.79	35 1.38	156 6.14	152 5.98	60 2.36	20 0.79	117 4.61	98.1
2	78	-	20 0.79	35 1.38	160 6.30	156 6.14	60 2.36	20 0.79	117 4.61	100.7
2	80	-	20 0.79	35 1.38	164 6.46	160 6.30	60 2.36	20 0.79	117 4.61	103.3
2	90	-	20 0.79	35 1.38	184 7.24	180 7.09	60 2.36	20 0.79	147 5.79	116.2
2	100	-	20 0.79	35 1.38	204 8.03	200 7.87	60 2.36	25 0.98	183 7.20	129.1





**Specification**

- Plastic Technopolymer (Polyamide PA)
  - Glass fiber reinforced
  - Temperature resistant up to 248 °F (120 °C)
  - Gray ● GR

---

- Plastic Technopolymer (Polyamide PA)
  - Glass fiber reinforced
  - Temperature resistant up to 248 °F (120 °C)
  - FDA compliant plastic granulate
  - Blue, RAL 5005, matte finish
  - Visually detectable ● VDB

---

- ISO Fundamental Tolerances
  - Standard Parts Handbook page 2129

---

- Plastic Characteristics
  - Standard Parts Handbook page 2135

---

- RoHS compliant

**On request**

- With keyway
- With bore H9

**Information**

Spur gears EN 7802 of plastic reduce both weight and noise while offering high corrosion resistance. Spur gears of polyamide allow the transmission of significantly higher torques compared with gears made of other plastics. This makes them especially suited for applications with high torques at low speeds.

The spur gears have involute toothing with a pressure angle of 20°. Further design details can be found in the technical information.

see also...

- General Notes for Gears → page 2
- Technical Instructions for Gears → page 3
- Product Family Standard Parts made of Detectable Plastics → page 2134
- Gear Racks EN 7822 → page 17

How to order <span style="font-size: 1.2em; font-weight: bold;">EN 7802-2-21-GR</span>	<table style="width: 100%; border-collapse: collapse;"> <tr> <td style="width: 20px; text-align: center; border-right: 1px solid black;">1</td> <td>Module</td> </tr> <tr> <td style="width: 20px; text-align: center; border-right: 1px solid black;">2</td> <td>Tooth count z</td> </tr> <tr> <td style="width: 20px; text-align: center; border-right: 1px solid black;">3</td> <td>Color</td> </tr> </table>	1	Module	2	Tooth count z	3	Color
1	Module						
2	Tooth count z						
3	Color						



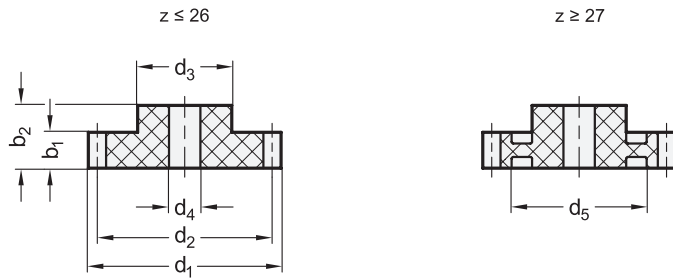

Dimensions in: millimeters - inches

Module	z Tooth count	b <sub>1</sub> Tooth width	b <sub>2</sub>	d <sub>1</sub>	d <sub>2</sub> Pitch circle Ø	d <sub>3</sub>	d <sub>4</sub> Pre-bored hole	d <sub>5</sub>	Max. torque in Nm
2.5	12	25 0.98	40 1.57	35 1.38	30 1.18	22 0.87	8 0.31	-	30.3
2.5	14	25 0.98	40 1.57	40 1.57	35 1.38	22 0.87	8 0.31	-	35.3
2.5	15	25 0.98	40 1.57	42.5 1.67	37.5 1.48	30 1.18	10 0.39	-	37.8
2.5	16	25 0.98	40 1.57	45 1.77	40 1.57	30 1.18	10 0.39	-	40.3
2.5	18	25 0.98	40 1.57	50 1.97	45 1.77	35 1.38	10 0.39	-	45.4
2.5	20	25 0.98	40 1.57	55 2.17	50 1.97	35 1.38	10 0.39	-	50.4
2.5	22	25 0.98	40 1.57	60 2.36	55 2.17	40 1.57	16 0.63	-	55.5
2.5	23	25 0.98	40 1.57	62.5 2.46	57.5 2.26	40 1.57	16 0.63	-	58
2.5	24	25 0.98	40 1.57	65 2.56	60 2.36	40 1.57	16 0.63	-	60.5
2.5	25	25 0.98	40 1.57	67.5 2.66	62.5 2.46	40 1.57	16 0.63	-	63
2.5	26	25 0.98	40 1.57	70 2.76	65 2.56	40 1.57	16 0.63	-	65.6
2.5	27	25 0.98	40 1.57	72.5 2.85	67.5 2.66	40 1.57	16 0.63	50 1.97	68.1
2.5	28	25 0.98	40 1.57	75 2.95	70 2.76	40 1.57	16 0.63	50 1.97	70.6
2.5	29	25 0.98	40 1.57	77.5 3.05	72.5 2.85	45 1.77	16 0.63	56 2.20	73.1
2.5	30	25 0.98	40 1.57	80 3.15	75 2.95	45 1.77	16 0.63	56 2.20	75.6
2.5	32	25 0.98	40 1.57	85 3.35	80 3.15	50 1.97	16 0.63	61 2.40	80.7
2.5	35	25 0.98	40 1.57	92.5 3.64	87.5 3.44	50 1.97	16 0.63	61 2.40	88.3
2.5	40	25 0.98	40 1.57	105 4.13	100 3.94	50 1.97	18 0.71	73 2.87	100.9
2.5	45	25 0.98	40 1.57	117.5 4.63	112.5 4.43	60 2.36	18 0.71	85 3.35	113.5
2.5	50	25 0.98	40 1.57	130 5.12	125 4.92	60 2.36	20 0.79	105 4.13	126.1

**Specification**

- Plastic  
Technopolymer (Polyamide PA)  
- Glass fiber reinforced  
- Temperature resistant up to 248 °F (120 °C)  
- Gray ● GR
- RoHS compliant

**On request**

- With keyway
- With bore H9

**Information**

Spur gears EN 7802 of plastic reduce both weight and noise while offering high corrosion resistance. Spur gears of polyamide allow the transmission of significantly higher torques compared with gears made of other plastics. This makes them especially suited for applications with high torques at low speeds. The spur gears have involute toothing with a pressure angle of 20°. Further design details can be found in the technical information.

<p>How to order</p> <p><b>EN 7802-2.5-45-GR</b></p>	1	Module
	2	Tooth count z
	3	Color

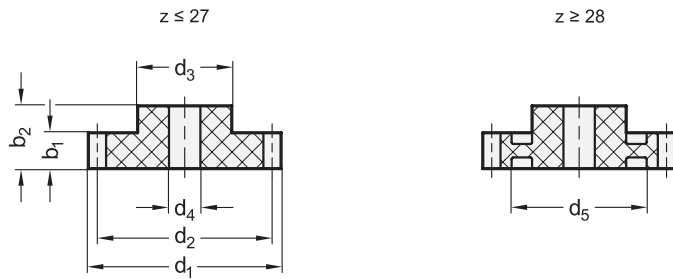

Dimensions in: millimeters - inches

Module	z Tooth count	b <sub>1</sub> Tooth width	b <sub>2</sub>	d <sub>1</sub>	d <sub>2</sub> Pitch circle Ø	d <sub>3</sub>	d <sub>4</sub> Pre-bored hole	d <sub>5</sub>	Max. torque in Nm
3	12	30 1.18	45 1.77	42 1.65	36 1.42	25 0.98	12 0.47	-	52.3
3	14	30 1.18	45 1.77	48 1.89	42 1.65	30 1.18	12 0.47	-	61
3	15	30 1.18	45 1.77	51 2.01	45 1.77	30 1.18	12 0.47	-	65.4
3	16	30 1.18	45 1.77	54 2.13	48 1.89	35 1.38	12 0.47	-	69.7
3	18	30 1.18	45 1.77	60 2.36	54 2.13	40 1.57	12 0.47	-	78.4
3	20	30 1.18	45 1.77	66 2.60	60 2.36	45 1.77	12 0.47	-	87.1
3	22	30 1.18	45 1.77	72 2.83	66 2.60	45 1.77	16 0.63	-	95.9
3	23	30 1.18	45 1.77	75 2.95	69 2.72	45 1.77	16 0.63	-	100.2
3	24	30 1.18	45 1.77	78 3.07	72 2.83	45 1.77	16 0.63	-	104.6
3	25	30 1.18	45 1.77	81 3.19	75 2.95	45 1.77	16 0.63	-	108.9
3	26	30 1.18	45 1.77	84 3.31	78 3.07	45 1.77	16 0.63	-	113.3
3	27	30 1.18	45 1.77	87 3.43	81 3.19	45 1.77	16 0.63	-	117.6
3	28	30 1.18	45 1.77	90 3.54	84 3.31	50 1.97	16 0.63	65 2.56	122
3	29	30 1.18	45 1.77	93 3.66	87 3.43	50 1.97	16 0.63	65 2.56	126.4
3	30	30 1.18	45 1.77	96 3.78	90 3.54	50 1.97	16 0.63	65 2.56	130.7
3	32	30 1.18	45 1.77	102 4.02	96 3.78	50 1.97	16 0.63	73 2.87	139.4
3	35	30 1.18	45 1.77	111 4.37	105 4.13	60 2.36	20 0.79	80 3.15	152.5
3	40	30 1.18	45 1.77	126 4.96	120 4.72	60 2.36	20 0.79	85 3.35	174.3
3	45	30 1.18	45 1.77	141 5.55	135 5.31	60 2.36	20 0.79	101 3.98	196.1
3	50	30 1.18	45 1.77	156 6.14	150 5.91	60 2.36	20 0.79	127 5.00	217.6

**Specification**

- Plastic  
Technopolymer (Polyamide PA)  
- Glass fiber reinforced  
- Temperature resistant up to 248 °F (120 °C)  
- Gray ● GR
- RoHS compliant

**On request**

- With keyway
- With bore H9

**Information**

Spur gears EN 7802 of plastic reduce both weight and noise while offering high corrosion resistance. Spur gears of polyamide allow the transmission of significantly higher torques compared with gears made of other plastics. This makes them especially suited for applications with high torques at low speeds. The spur gears have involute toothing with a pressure angle of 20°. Further design details can be found in the technical information.

<b>How to order</b> <b>EN 7802-3-50-GR</b>	1 2 3	<b>1</b> Module
		<b>2</b> Tooth count z
		<b>3</b> Color

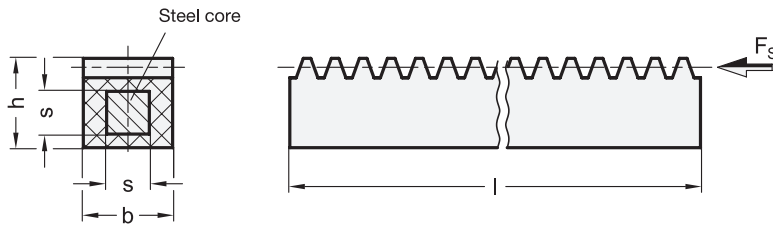

Application example

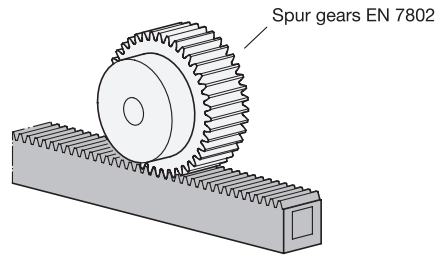

**3 Type**

**VG** Square, straight, toothed

Dimensions in: millimeters - inches

Module	Length l		b Tooth width	h	s	Max. force $F_s$ acting on a tooth
	Nominal size	Actual size				
1	350 13.78	352 13.86	15 0.59	15 0.59	8 0.31	372 N 83.63 lbf
1.5	250 9.84	250 9.84	17 0.67	17 0.67	8 0.31	633 N 142.30 lbf
1.5	500 19.69	565 22.24	17 0.67	17 0.67	8 0.31	633 N 142.30 lbf
2	250 9.84	251 9.88	20 0.79	20 0.79	10 0.39	993 N 223.24 lbf
2	500 19.69	565 22.24	20 0.79	20 0.79	10 0.39	993 N 223.24 lbf
3	250 9.84	254 10.00	30 1.18	30 1.18	15 0.59	2234 N 502.22 lbf
3	500 19.69	500 19.69	30 1.18	30 1.18	15 0.59	2234 N 502.22 lbf

**Specification**

- Plastic  
Technopolymer (Polyamide PA)  
- Glass fiber reinforced  
- Temperature resistant up to 248 °F (120 °C)  
- Gray ● GR
- *Plastic Characteristics* → page 2135
- **RoHS compliant**

**On request**

- Other types

**Information**

Gear racks EN 7822 are used in combination with spur gears EN 7802 to convert rotary motion into linear motion. They are used in automation applications with high repeatable precision and frequent changes of direction and load.

The steel core increases the stiffness and prevents bending of the racks. In addition, modules 1 / 1.5 / 2 are designed for continuous installation of the racks.

The gear racks have a reference profile toothing with a pressure angle of 20°. The force  $F_s$  refers to the maximum permissible force that can be applied to a single tooth.

see also...

- *General Notes for Gears* → page 2
- *Technical Instructions for Gears* → page 3

How to order	
1	Module
2	Length l
3	Type
4	Color

**EN 7822-1.5-250-VG-GR**

**J.W. Winco, Inc.\***

2815 South Calhoun Road  
New Berlin, WI 53151  
USA

**Phone** +1-800-877-8351

**E-Mail** sales@jwwinco.com

\*ISO 9001 certified

**J.W. Winco Canada, Inc.**

300 Trowers Rd, Unit 11,  
Woodbridge, ON L4L 5Z9  
Canada

**Phone** +1-800-397-6993

**E-Mail** sales@jwwinco.ca

**JW Winco México, S.A. de C.V.**

Parque Industrial Makro, Bodega 10  
Santa Catarina, N.L. 66359  
México

**Phone** +52(81)2721-4021

**E-Mail** ventas@jwwinco.mx

**[www.jwwinco.com](http://www.jwwinco.com)**