

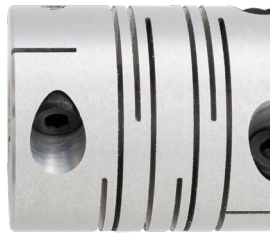

JW WINCO[®]
A Ganter Company

Highlights

Couplings

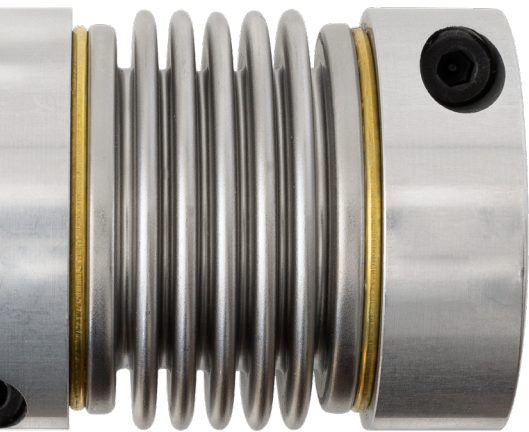

Standard Parts. **Winco.**

Contents

Couplings

Product Index	→ page 2
General Information	→ page 4
Overview of Types	→ page 6
<hr/>	
Elastomer Jaw Couplings GN 2240	→ page 8
Elastomer Jaw Couplings GN 2241	→ page 11
Oldham Couplings GN 2242	→ page 14
Oldham Couplings GN 2243	→ page 16
Bellows Couplings GN 2244	→ page 18
Beam Couplings GN 2246	→ page 20
Coupling Spiders GN 2240.1	→ page 22
<hr/>	
Application Example	→ page 23
Installation Information	→ page 24
Technical Information / Definition of Terms	→ page 26

The publication of this catalog renders all previous editions invalid. All editions meet the best available technology during printing. We reserve the right to make technical modifications or modifications resulting from an error as well as the right to remove individual items from the product range. The products of this catalog were developed as standard parts with the aim of covering the widest possible spectrum of requirements. We shall not assume any responsibility or liability for special applications with extraordinary requirements on our products. Our design department will gladly answer questions on certain product features, such as missing tolerances, dimensions, and stability. We will deliver based on our terms and conditions of payment and delivery. Download is available at www.jwwinco.com. J.W. Winco, Inc. has all rights to the catalog. Reproduction, including excerpts, is prohibited.
J.W. Winco, Inc., March 2022

Couplings



**GN 2240
Elastomer Jaw Couplings**
with Clamping Hub
Aluminum
[Page 8](#)



**GN 2241
Elastomer Jaw Couplings**
Hub with Set Screw
Aluminum
[Page 11](#)



**GN 2242
Oldham Couplings**
with Clamping Hub
Aluminum
[Page 14](#)



**GN 2243
Oldham Couplings**
Hub with Set Screw
Aluminum
[Page 16](#)



**GN 2244
Bellows Couplings**
with Clamping Hub
Stainless Steel
[Page 18](#)



**GN 2246
Beam Couplings**
with Clamping Hub
Aluminum
[Page 20](#)



**GN 2246
Beam Couplings**
with Clamping Hub
Stainless Steel
[Page 20](#)

Accessory



**GN 2240.1
Coupling Spiders**
for GN 2240 / GN 2241
Thermoplastic Polyurethane
[Page 22](#)



Introduction

Couplings create connections between drive shafts and driven shafts in order to transmit rotary motion and torque. For example, they are used to combine the shafts of motors and transmissions into a single drive unit.

Alongside the primary purpose of transmitting torque, couplings also carry out other important tasks:

- Compensating for shaft offsets and misalignments
- Absorbing runout errors and axial motions
- Damping vibrations and shocks

Couplings are used in a very wide range of applications. The spectrum ranges from simple drives to complex control, regulation and measurement applications.

Misalignment and runout tolerances

Like all mechanical parts, shafts are subjected to manufacturing and assembly tolerances that generally cannot be entirely eliminated even with extensive technical measures.

If these deviations are not taken into account in the design, the result can be vibrations, running noises, and wear or damage to the shafts and their bearings.

Suitable couplings not only are able to effectively compensate for misalignment and runout errors, they also greatly simplify the assembly process, thereby reducing the overall labor required.

Shaft misalignment and runout errors can vary in nature and should always be taken into consideration when selecting the appropriate coupling.

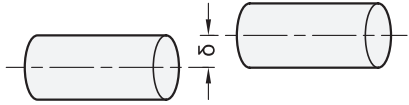
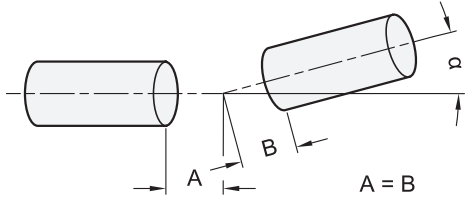
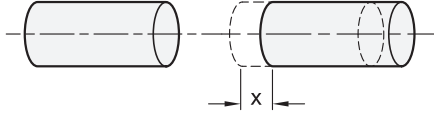
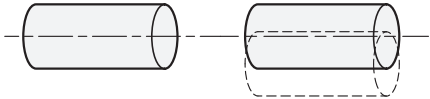
Error type	Misalignment diagram
<p>Lateral The axes of the shafts are in fact parallel, but they are offset laterally and do not line up.</p>	
<p>Angular The axes of the shafts do not lie in the same plane; they meet at a certain angle.</p>	
<p>Axial The shafts move axially along the axis of rotation.</p>	
<p>Runout The shafts move radially out of the center of the axis of rotation.</p>	

Areas of application - Classes - Coupling types

The applications of couplings can generally be divided into two classes.

Motion control

For motion control applications, the rotational movement is transmitted with very high precision and accuracy. This requires a coupling type with a high torsional stiffness and zero backlash in the direction of rotation.

Typical applications are:

Servo or stepper motors for linear axes, industrial robots, test benches, etc.

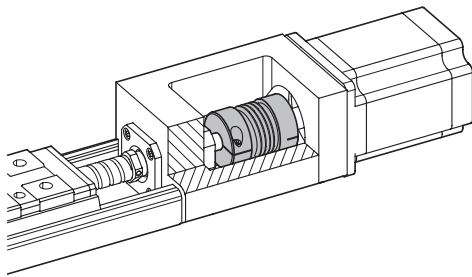

Torque and power transmission

For torque and power transmission, the focus lies on pure transmission of force. This requires couplings that can withstand high torques and heavy loads while functioning reliably in harsh conditions.

Typical applications are:

Conveyor systems, pumps and agitators, packaging machines, etc.

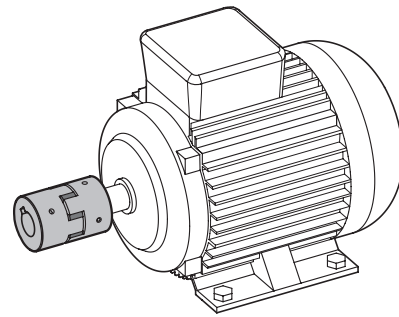

Two coupling types are available for each of the application classes described above.

Bellows couplings and beam couplings

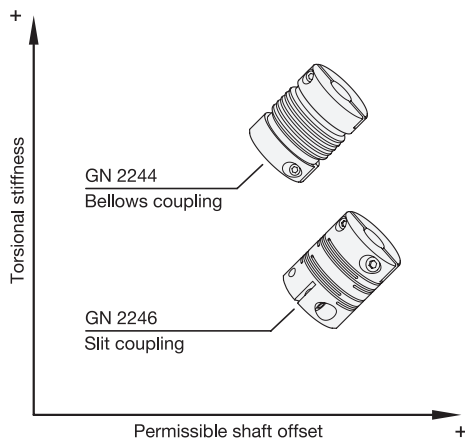

Bellows couplings offer high torsional stiffness. This makes them excellent for precise and controlled movements.

Beam couplings have lower torsional stiffness compared with bellows couplings, but they can compensate for higher shaft misalignments.



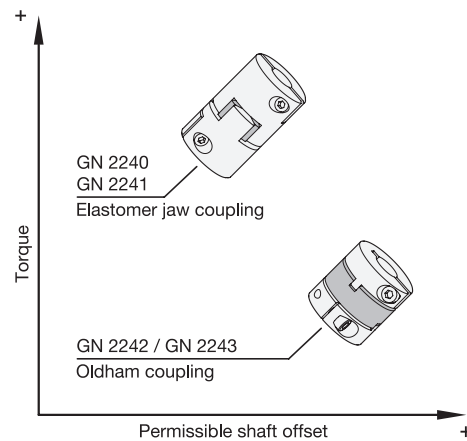





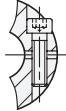

Elastomer jaw couplings and oldham couplings

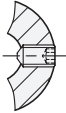

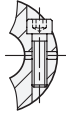
Elastomer jaw couplings are designed for high torque transmission and can be used in all manner of applications.

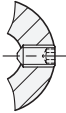
Oldham couplings transmit less torque but can compensate for higher shaft misalignments.

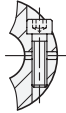
Dimensions in: millimeters - inches

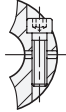
Series	Shaft Ø	Hub clamping	Rated torque in Nm	Misalignment			Zero backlash
				axial	lateral	angular	
GN 2240 Page 8 Elastomer jaw couplings	 3 - 25 0.12 - 0.98		0.7 - 60	x	x	x	
GN 2241 Page 11 Elastomer jaw couplings	 3 - 25 0.12 - 0.98		0.7 - 60	x	x	x	
GN 2242 Page 14 Oldham couplings	 4 - 20 0.16 - 0.79		1 - 28		x	x	
GN 2243 Page 16 Oldham couplings	 2 - 20 0.08 - 0.79		0.5 - 28		x	x	
GN 2244 Page 18 Bellows couplings	 5 - 19 0.20 - 0.75		1.5 - 10	x	x	x	x
GN 2246 Page 20 Beam couplings	 4 - 12 0.16 - 0.47		0.3 - 4	x	x	x	x

Series	Suitable for use with			Application examples	Special features
	Servo motors	Stepper motors	Universal motors		
GN 2240 Page 8 Elastomer jaw couplings	x	x	x	<ul style="list-style-type: none"> - Hydraulic pumps - Packaging machines - Industrial robots - Fans - Agitators 	<ul style="list-style-type: none"> - High torques - Fast and simple plug-in assembly
GN 2241 Page 11 Elastomer jaw couplings	x	x	x		
GN 2242 Page 14 Oldham couplings		x	x	<ul style="list-style-type: none"> - Conveyor systems - Packaging machines - Positioning drives - Pumps 	<ul style="list-style-type: none"> - High torques - High lateral misalignment compensation - Fast and simple plug-in assembly
GN 2243 Page 16 Oldham couplings		x	x		
GN 2244 Page 18 Bellows couplings	x	x		<ul style="list-style-type: none"> - Rotary encoders - Position measuring systems - Test benches - Industrial robots - Spindle drives 	<ul style="list-style-type: none"> - Precise angle and torque transmission - High torsional stiffness
GN 2246 Page 20 Beam couplings		x		<ul style="list-style-type: none"> - Confectionery machines - Industrial robots - CAT scanners - Position measuring systems 	<ul style="list-style-type: none"> - Precise angle and torque transmission - Manufactured from a single piece - High torsional stiffness

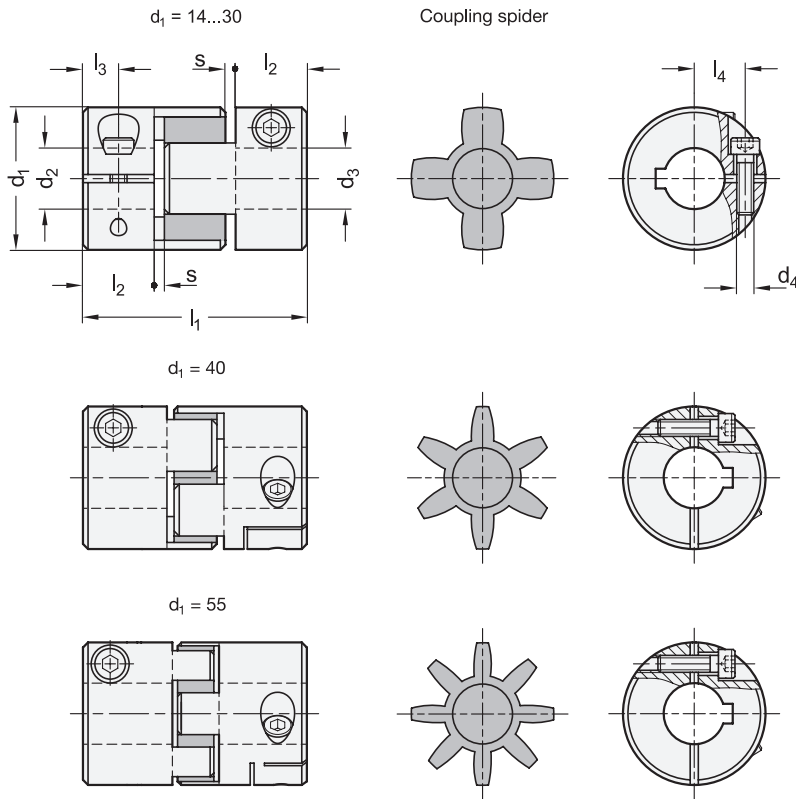

2 Bore code
B Without keyway
K With keyway (from $d_1 = 30$)

Assembly instruction

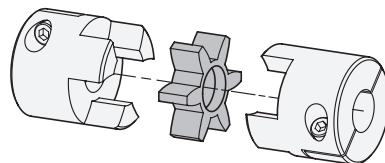

Specification

- Hub
Aluminum **AL**
Anodized finish, natural color
- Coupling spider
Thermoplastic Polyurethane (TPU)
Temperature resistant up to 140 °F (60 °C)
Hardness
80 shore A, blue **BS**
92 shore A, white **WS**
98 shore A, red **RS**
- Socket cap screws DIN 912
Steel, blackened finish
- Temperature range from: -4 °F up to +140 °F
(-20 °C up to +60 °C)
- Keyways WN / DIN 6885
→ *Standard Parts Handbook page 2039 / 2040*
- ISO Fundamental Tolerances
→ *Standard Parts Handbook page 2129*
- Elastomer Characteristics
→ *Standard Parts Handbook page 2135*
- RoHS compliant

Accessory

- Coupling spiders GN 2240.1 → *page 22*

Information

Elastomer jaw couplings GN 2240 can transmit very high torques while compensating for shaft misalignments and runout tolerances. They are preferred in applications where the focus lies on pure torque and power transmission.

The choice of three coupling spiders with different hardness values allows the properties of the coupling to be optimally matched to the specific requirements. The clamping hubs and simple plug-in installation make jaw couplings very easy to assemble.

With the bore code K, the keyway is always integrated into both bores d_2 and d_3 .

see also...

- *Elastomer Jaw Couplings GN 2241 (with Set Screw) → page 11*
- *Oldham Couplings GN 2242 (with Clamping Hub) → page 14*
- *Installation Information on Couplings → page 24*
- *Technical Information on Couplings → page 26*

How to order	
1	Outside diameter d_1
2	Bore code
3	Bore d_2 - d_3
4	Material
5	Hardness

GN 2240-14- B3/16 - 3/16 -AL-RS

Jaw couplings with inch-inch bore

Dimensions in: inches - millimeters

d₁	d₂ - d₃ +0.001 Bore (in-in) Recommended shaft tolerance -0.001									
0.55 14	3/16-3/16	3/16-1/4	1/4-1/4	-	-	-	-	-	-	-
0.79 20	3/16-3/16	3/16-1/4	3/16-5/16	3/16-3/8	1/4-1/4	1/4-5/16	1/4-3/8	5/16-5/16	5/16-3/8	3/8-3/8
1.18 30	5/16-5/16	5/16-3/8	5/16-1/2	5/16-5/8	3/8-3/8	3/8-1/2	3/8-5/8	1/2-1/2	1/2-5/8	5/8-5/8
1.57 40	3/8-3/8	3/8-1/2	3/8-5/8	3/8-3/4	1/2-1/2	1/2-5/8	1/2-3/4	5/8-5/8	5/8-3/4	3/4-3/4
2.17 55	1/2-1/2	1/2-5/8	1/2-3/4	1/2-7/8	5/8-5/8	5/8-3/4	5/8-7/8	3/4-3/4	3/4-7/8	7/8-7/8

d₁	d₄ Thread	l₁	l₂ Recommended shaft insertion depth	l₃	l₄	s Recommended installation spacing
0.55 14	M 2 / M 1.6*	0.87 22	0.28 7	0.14 3.5	0.16 / 0.20* 4 / 5	0.04 1
0.79 20	M 2.5 / M 2**	1.18 30	0.39 10	0.20 5	0.26 / 0.30** 6.5 / 7.5	0.04 1
1.18 30	M 4 / M 3***	1.38 35	0.43 11	0.22 5.5	0.39 / 0.43*** 10 / 11	0.06 1.5
1.57 40	M 5	2.60 66	0.98 25	0.33 8.5	0.55 14	0.08 2
2.17 55	M 6	3.07 78	1.18 30	0.41 10.5	0.79 20	0.08 2

* for bore d₂ / d₃ = 1/4 ** for bore d₂ / d₃ = 3/8 *** for bore d₂ / d₃ ≥ 1/2

Jaw couplings with metric-metric bore

Dimensions in: millimeters - inches

d₁	d₂ - d₃ H8 Bore (mm-mm) Recommended shaft tolerance h7									
14 0.55	3-3	3-4	3-5	3-6	4-4	4-5	4-6	5-5	5-6	6-6
20 0.79	5-5	5-6	5-8	6-6	6-8	8-8	-	-	-	-
30 1.18	8-8	8-10	8-12	8-14	10-10	10-12	10-14	12-12	12-14	14-14
40 1.57	12-12	12-14	12-15	12-16	14-14	14-15	14-16	15-15	15-16	16-16
55 2.17	18-18	18-19	18-20	18-25	19-19	19-20	19-25	20-20	20-25	25-25

d₁	d₄ Thread	l₁	l₂ Recommended shaft insertion depth	l₃	l₄	s Recommended installation spacing
14 0.55	M 2 / M 1.6*	22 0.87	7 0.28	3.5 0.14	4 / 5* 0.16 / 0.20	1 0.04
20 0.79	M 2.5	30 1.18	10 0.39	5 0.20	6.5 0.26	1 0.04
30 1.18	M 4 / M 3**	35 1.38	11 0.43	5.5 0.22	10 / 11** 0.39 / 0.43	1.5 0.06
40 1.57	M 5	66 2.60	25 0.98	8.5 0.33	14 0.55	2 0.08
55 2.17	M 6	78 3.07	30 1.18	10.5 0.41	20 0.79	2 0.08

* for bore d₂ / d₃ = 6 ** for bore d₂ / d₃ = 14

Jaw couplings with metric-inch bore

1

3

Dimensions in: millimeters - inches

d ₁	d ₂ - d ₃ H8 Bore (mm-in) Recommended shaft tolerance h7															
14 0.55	3-3/16	3-1/4	4-3/16	4-1/4	5-3/16	5-1/4	6-3/16	6-1/4	-	-	-	-	-	-	-	-
20 0.79	5-3/16	5-1/4	5-5/16	5-3/8	6-3/16	6-1/4	6-5/16	6-3/8	8-3/16	8-1/4	8-5/16	8-3/8	-	-	-	-
30 1.18	8-5/16	8-3/8	8-1/2	8-5/8	10-5/16	10-3/8	10-1/2	10-5/8	12-5/16	12-3/8	12-1/2	12-5/8	14-5/16	14-3/8	14-1/2	14-5/8
40 1.57	12-3/8	12-1/2	12-5/8	12-3/4	14-3/8	14-1/2	14-5/8	14-3/4	15-3/8	15-1/2	15-5/8	15-3/4	16-3/8	16-1/2	16-5/8	16-3/4
55 2.17	18-1/2	18-5/8	18-3/4	18-7/8	19-1/2	19-5/8	19-3/4	19-7/8	20-1/2	20-5/8	20-3/4	20-7/8	25-1/2	25-5/8	25-3/4	25-7/8

d ₁	d ₄ Thread	l ₁	l ₂ Recommended shaft insertion depth	l ₃	l ₄	s Recommended installation spacing
14 0.55	M 2 / M 1.6*	22 0.87	7 0.28	3.5 0.14	4 / 5* 0.16 / 0.20	1 0.04
20 0.79	M 2.5 / M 2**	30 1.18	10 0.39	5 0.20	6.5 / 7.5** 0.26 / 0.30	1 0.04
30 1.18	M 4 / M 3***	35 1.38	11 0.43	5.5 0.22	10 / 11*** 0.39 / 0.43	1.5 0.06
40 1.57	M 5	66 2.60	25 0.98	8.5 0.33	14 0.55	2 0.08
55 2.17	M 6	78 3.07	30 1.18	10.5 0.41	20 0.79	2 0.08

* for bore d₂ = 6 ** for bore d₃ = 3/8 *** for bore d₂ = 14
* for bore d₃ = 1/4 *** for bore d₃ = 1/2 *** for bore d₃ = 5/8

Dimensions in: millimeters - inches

d ₁	Coupling spider	Shore hardness coupling spider	Rated torque in Nm	Max. torque in Nm	Max. speed (min ⁻¹)	Moment of inertia in kgm ²	Static torsional stiffness in Nm/rad	Max. shaft misalignment		
								Lateral	Axial	Angular in °
14 0.55	BS	80A	0.7	1.4	45,000	2.0 x 10 ⁻⁷	8	0.15 0.006	0.6 0.024	1
	WS	92A	1.2	2.4	45,000	2.0 x 10 ⁻⁷	14	0.1 0.004	0.6 0.024	1
	RS	98A	2	4	45,000	2.0 x 10 ⁻⁷	22	0.1 0.004	0.6 0.024	1
20 0.79	BS	80A	1.8	3.6	31,000	1.1 x 10 ⁻⁶	16	0.2 0.008	0.8 0.031	1
	WS	92A	3	6	31,000	1.1 x 10 ⁻⁶	29	0.15 0.006	0.8 0.031	1
	RS	98A	5	10	31,000	1.1 x 10 ⁻⁶	55	0.1 0.004	0.8 0.031	1
30 1.18	BS	80A	4	8	21,000	6.2 x 10 ⁻⁶	46	0.2 0.008	1 0.039	1
	WS	92A	7.5	15	21,000	6.2 x 10 ⁻⁶	73	0.15 0.006	1 0.039	1
	RS	98A	12.5	25	21,000	6.2 x 10 ⁻⁶	130	0.1 0.004	1 0.039	1
40 1.57	BS	80A	4.9	9.8	15,000	3.7 x 10 ⁻⁵	380	0.15 0.006	1.2 0.047	1
	WS	92A	10	20	15,000	3.7 x 10 ⁻⁵	570	0.1 0.004	1.2 0.047	1
	RS	98A	17	34	15,000	3.7 x 10 ⁻⁵	1200	0.1 0.004	1.2 0.047	1
55 2.17	BS	80A	17	34	11,000	1.6 x 10 ⁻⁴	1400	0.2 0.008	1.4 0.055	1
	WS	92A	35	70	11,000	1.6 x 10 ⁻⁴	1600	0.15 0.006	1.4 0.055	1
	RS	98A	60	120	11,000	1.6 x 10 ⁻⁴	2600	0.1 0.004	1.4 0.055	1

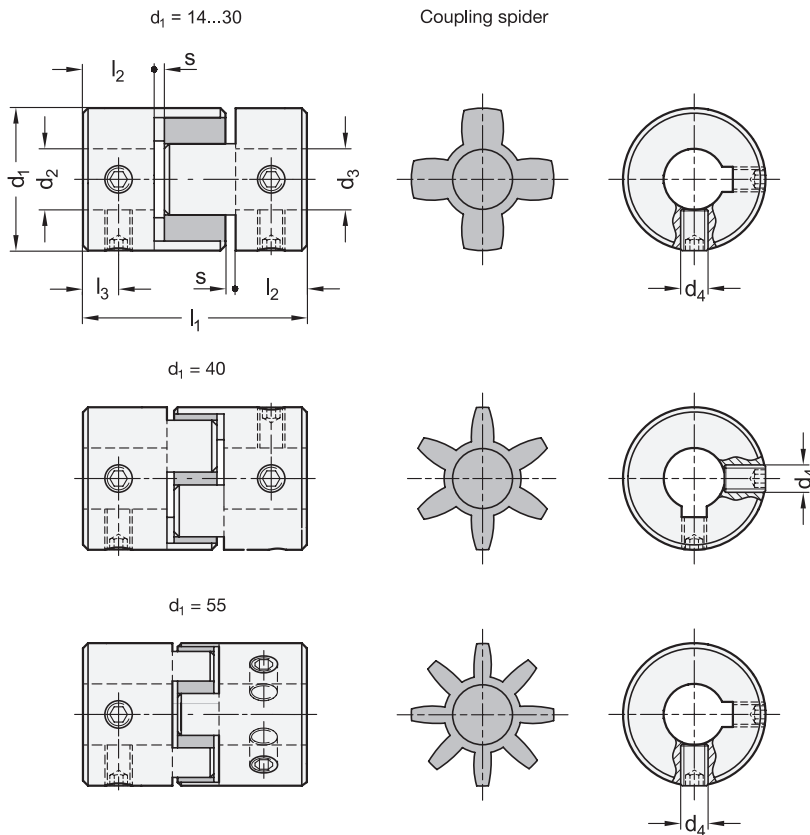

- 2 Bore code**
- B** Without keyway
 - K** With keyway (from $d_1 = 30$)

Assembly instruction

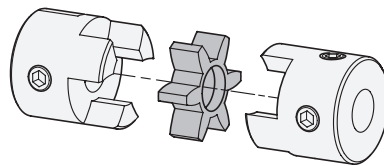

Specification

- Hub
Aluminum **AL**
Anodized finish, natural color
- Coupling spider
Thermoplastic Polyurethane (TPU)
Temperature resistant up to 140 °F (60 °C)
Hardness
80 shore A, blue **BS**
92 shore A, white **WS**
98 shore A, red **RS**
- Set screws
- Steel, blackened finish
- For $d_2 / d_3 \leq 4$, one set screw
- For $d_2 / d_3 > 4$, two set screws
- Temperature range: -4 °F up to +140 °F
(-20 °C up to +60 °C)
- Keyways *WN / DIN 6885*
→ *Standard Parts Handbook page 2039 / 2040*
- *ISO Fundamental Tolerances*
→ *Standard Parts Handbook page 2129*
- *Elastomer Characteristics*
→ *Standard Parts Handbook page 2135*
- **RoHS compliant**

Accessory

- Coupling spiders GN 2240.1 → page 22

Information

Elastomer jaw couplings GN 2241 can transmit very high torques while compensating for shaft misalignments and runout tolerances. They are preferred in applications where the focus lies on pure torque and power transmission.

The choice of three coupling spiders with different hardness values allows the properties of the coupling to be optimally matched to the specific requirements. The use of set screws for clamping and the simple plug-in installation make jaw couplings very easy to assemble.

With the bore code K, the keyway is always integrated into both bores d_2 and d_3 .

see also...

- *Elastomer Jaw Couplings GN 2240 (with Clamping Hub)* → page 8
- *Oldham Couplings GN 2243 (Hub with Set Screw)* → page 16
- *Installation Information on Couplings* → page 24
- *Technical Information on Couplings* → page 26

How to order	
1	Outside diameter d_1
2	Bore code
3	Bore d_2 - d_3
4	Material
5	Hardness

GN 2241-14-B1/4-1/4-AL-BS

Jaw couplings with inch-inch bore

Dimensions in: inches - *millimeters*

d₁	d₂ - d₃ +0.001 Bore (in-in) Recommended shaft tolerance -0.001									
0.55 14	3/16-3/16	3/16-1/4	1/4-1/4	-	-	-	-	-	-	-
0.79 20	3/16-3/16	3/16-1/4	3/16-5/16	3/16-3/8	1/4-1/4	1/4-5/16	1/4-3/8	5/16-5/16	5/16-3/8	3/8-3/8
1.18 30	5/16-5/16	5/16-3/8	5/16-1/2	5/16-5/8	3/8-3/8	3/8-1/2	3/8-5/8	1/2-1/2	1/2-5/8	5/8-5/8
1.57 40	3/8-3/8	3/8-1/2	3/8-5/8	3/8-3/4	1/2-1/2	1/2-5/8	1/2-3/4	5/8-5/8	5/8-3/4	3/4-3/4
2.17 55	1/2-1/2	1/2-5/8	1/2-3/4	1/2-7/8	5/8-5/8	5/8-3/4	5/8-7/8	3/4-3/4	3/4-7/8	7/8-7/8

Jaw couplings with metric-metric bore

Dimensions in: millimeters - *inches*

d₁	d₂ - d₃ H8 Bore (mm-mm) Recommended shaft tolerance h7									
14 0.55	3-3	3-4	3-5	3-6	4-4	4-5	4-6	5-5	5-6	6-6
20 0.79	5-5	5-6	5-8	6-6	6-8	8-8	-	-	-	-
30 1.18	8-8	8-10	8-12	8-14	10-10	10-12	10-14	12-12	12-14	14-14
40 1.57	12-12	12-14	12-15	12-16	14-14	14-15	14-16	15-15	15-16	16-16
55 2.17	18-18	18-19	18-20	18-25	19-19	19-20	19-25	20-20	20-25	25-25

Jaw couplings with metric-inch bore

Dimensions in: millimeters - *inches*

d₁	d₂ - d₃ H8 Bore (mm-in) Recommended shaft tolerance h7															
14 0.55	3-3/16	3-1/4	4-3/16	4-1/4	5-3/16	5-1/4	6-3/16	6-1/4	-	-	-	-	-	-	-	-
20 0.79	5-3/16	5-1/4	5-5/16	5-3/8	6-3/16	6-1/4	6-5/16	6-3/8	8-3/16	8-1/4	8-5/16	8-3/8	-	-	-	-
30 1.18	8-5/16	8-3/8	8-1/2	8-5/8	10-5/16	10-3/8	10-1/2	10-5/8	12-5/16	12-3/8	12-1/2	12-5/8	14-5/16	14-3/8	14-1/2	14-5/8
40 1.57	12-3/8	12-1/2	12-5/8	12-3/4	14-3/8	14-1/2	14-5/8	14-3/4	15-3/8	15-1/2	15-5/8	15-3/4	16-3/8	16-1/2	16-5/8	16-3/4
55 2.17	18-1/2	18-5/8	18-3/4	18-7/8	19-1/2	19-5/8	19-3/4	19-7/8	20-1/2	20-5/8	20-3/4	20-7/8	25-1/2	25-5/8	25-3/4	25-7/8

d₁	d₄ Thread	l₁	l₂ Recommended shaft insertion depth	l₃	s Recommended installation spacing	Tightening torque of the screw in Nm ≈
14 0.55	M 3	22 0.87	7 0.28	3.5 0.14	1 0.039	0.7
20 0.79	M 3	30 1.18	10 0.39	5 0.20	1 0.039	0.7
30 1.18	M 4	35 1.38	11 0.43	5.5 0.22	1.5 0.059	1.7
40 1.57	M 5	66 2.60	25 0.98	8.5 0.33	2 0.079	4
55 2.17	M 6	78 3.07	30 1.18	10.5 0.41	2 0.079	7

Dimensions in: millimeters - inches

d ₁	Coupling spider	Shore hardness coupling spider	Rated torque in Nm	Max. torque in Nm	Max. speed (min ⁻¹)	Moment of inertia in kgm ²	Static torsional stiffness in Nm/rad	Max. shaft misalignment		
								Lateral	Axial	Angular in °
14 0.55	BS	80A	0.7	1.4	45,000	2.0 x 10 ⁻⁷	8	0.15 0.006	0.6 0.024	1
	WS	92A	1.2	2.4	45,000	2.0 x 10 ⁻⁷	14	0.1 0.004	0.6 0.024	1
	RS	98A	2	4	45,000	2.0 x 10 ⁻⁷	22	0.1 0.004	0.6 0.024	1
20 0.79	BS	80A	1.8	3.6	31,000	1.1 x 10 ⁻⁶	16	0.2 0.008	0.8 0.031	1
	WS	92A	3	6	31,000	1.1 x 10 ⁻⁶	29	0.15 0.006	0.8 0.031	1
	RS	98A	5	10	31,000	1.1 x 10 ⁻⁶	55	0.1 0.004	0.8 0.031	1
30 1.18	BS	80A	4	8	21,000	6.2 x 10 ⁻⁶	46	0.2 0.008	1 0.039	1
	WS	92A	7.5	15	21,000	6.2 x 10 ⁻⁶	73	0.15 0.006	1 0.039	1
	RS	98A	12.5	25	21,000	6.2 x 10 ⁻⁶	130	0.1 0.004	1 0.039	1
40 1.57	BS	80A	4.9	9.8	15,000	3.7 x 10 ⁻⁵	380	0.15 0.006	1.2 0.047	1
	WS	92A	10	20	15,000	3.7 x 10 ⁻⁵	570	0.1 0.004	1.2 0.047	1
	RS	98A	17	34	15,000	3.7 x 10 ⁻⁵	1200	0.1 0.004	1.2 0.047	1
55 2.17	BS	80A	17	34	11,000	1.6 x 10 ⁻⁴	1400	0.2 0.008	1.4 0.055	1
	WS	92A	35	70	11,000	1.6 x 10 ⁻⁴	1600	0.15 0.006	1.4 0.055	1
	RS	98A	60	120	11,000	1.6 x 10 ⁻⁴	2600	0.1 0.004	1.4 0.055	1

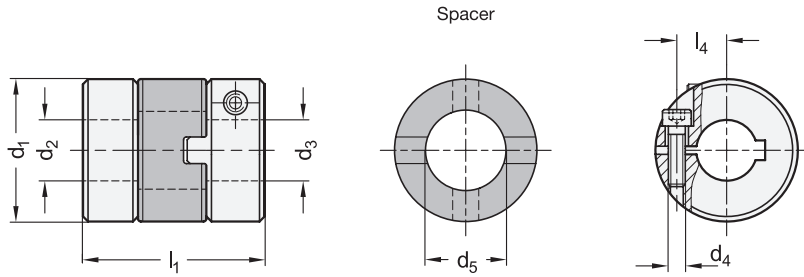

2 Bore code
B Without keyway
K With keyway

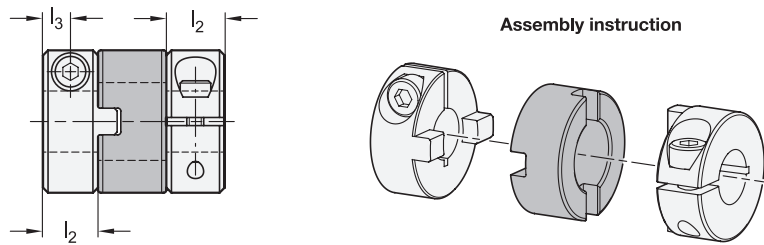

Oldham couplings with inch-inch bore

Dimensions in: inches - *millimeters*

1 d_1	3 $d_2 - d_3 +0.001$ Bore (in-in) Recommended shaft tolerance -0.001					
0.79 20	1/4-1/4*	1/4-5/16*	1/4-3/8*	5/16-5/16	5/16-3/8	3/8-3/8
1.18 30	3/8-3/8	3/8-1/2	1/2-1/2	-	-	-
1.50 38	1/2-1/2	1/2-5/8	1/2-3/4	5/8-5/8	5/8-3/4	3/4-3/4

*Only available with bore code B

Oldham couplings with metric-metric bore

Dimensions in: millimeters - *inches*

1 d_1	3 $d_2 - d_3$ H8 Bore (mm-mm) Recommended shaft tolerance h7					
12 0.47	4-4	4-5	5-5	-	-	-
15 0.59	4-4	4-5	4-6	5-5	5-6	6-6
20 0.79	6-6	6-8	6-10	8-8	8-10	10-10
30 1.18	8-8	8-10	8-12	10-10	10-12	12-12
38 1.50	12-12	12-15	12-20	15-15	15-20	20-20

Oldham couplings with metric-inch bore

Dimensions in: millimeters - *inches*

1 d_1	3 $d_2 - d_3$ H8 Bore (mm-in) Recommended shaft tolerance h7								
20 0.79	6-1/4*	6-5/16	6-3/8	8-1/4*	8-5/16	8-3/8	10-1/4*	10-5/16	10-3/8
30 1.18	8-3/8	8-1/2	10-3/8	10-1/2	12-3/8	12-1/2	-	-	-
38 1.50	12-1/2	12-5/8	12-3/4	15-1/2	15-5/8	15-3/4	20-1/2	20-5/8	20-3/4

*Only available with bore code B

Dimensions in: millimeters - inches

d ₁	d ₄ Thread	d ₅	l ₁	l ₂ Recommended shaft insertion depth	l ₃	l ₄
12 0.47	M 2	5.2 0.20	19 0.75	6.2 0.24	3.1 0.12	4 0.16
15 0.59	M 2.5	8.2 0.32	21.2 0.83	7 0.28	3.5 0.14	5 0.20
20 0.79	M 3	12.2 0.48	27 1.06	8.8 0.35	4.4 0.17	7.5 0.30
30 1.18	M 4	16.2 0.64	32.5 1.28	10 0.39	5 0.20	11.1 0.44
38 1.50	M 5	20.3 0.80	40 1.57	12.1 0.48	6 0.24	14.2 0.56

d ₁	Rated torque in Nm*	Max. torque in Nm*	Max. speed (min ⁻¹)	Moment of inertia in kgm ²	Static torsional stiffness in Nm/rad	Max. shaft misalignment	
						Lateral	Angular in °
12 0.47	1	2	52,000	6.6 x 10 ⁻⁸	60	1 0.039	3
15 0.59	1.6	3.2	42,000	1.7 x 10 ⁻⁷	80	1 0.039	3
20 0.79	3.2	6.4	31,000	8.0 x 10 ⁻⁷	120	1.2 0.047	3
30 1.18	15	30	21,000	5.3 x 10 ⁻⁶	530	2 0.079	3
38 1.50	28	56	16,000	1.5 x 10 ⁻⁵	1500	2.5 0.098	3

*Load fluctuations are not taken into account

Specification



- Hub
Aluminum **AL**
Anodized finish, natural color
- Spacer
Plastic (Polyacetal POM) **KU**
Temperature resistant up to 176 °F (80 °C)
- Socket cap screws DIN 912
Steel, blackened finish
- Temperature range from: -4 °F up to +176 °F
(-20 °C up to +80 °C)
- Keyways WN / DIN 6885
→ *Standard Parts Handbook page 2039 / 2040*
- ISO Fundamental Tolerances
→ *Standard Parts Handbook page 2129*
- Plastic Characteristics
→ *Standard Parts Handbook page 2135*
- RoHS compliant

Information

Oldham couplings GN 2242 can compensate for large lateral shaft misalignments while transmitting high torques. As a result, they are used in applications with a focus on pure torque and power transmission associated with high lateral shaft misalignments.

The clamping hubs and simple plug-in installation make oldham couplings very easy to assemble. They are suitable for a diverse range of applications and are used in general machine construction in packaging machines and pumps.

With the bore code K, the keyway is always integrated into both bores d₂ and d₃.

see also...

- *Elastomer Jaw Couplings GN 2240 (with Clamping Hub) → page 8*
- *Oldham Couplings GN 2243 (Hub with Set Screw) → page 16*
- *Installation Information on Couplings → page 24*
- *Technical Information on Couplings → page 26*

How to order

GN 2242-20-B1/4-3/8-AL-KU

- | | |
|---|-------------------------------------|
| 1 | Outside diameter d ₁ |
| 2 | Bore code |
| 3 | Bore d ₂ -d ₃ |
| 4 | Material (Hub) |
| 5 | Material (Spacer) |

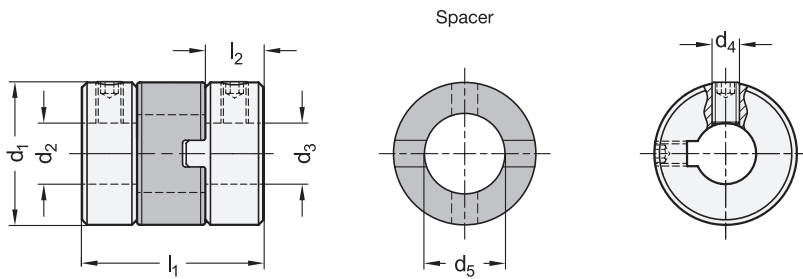

2 Bore code

- B** Without keyway
- K** With keyway (from $d_1 = 20$)

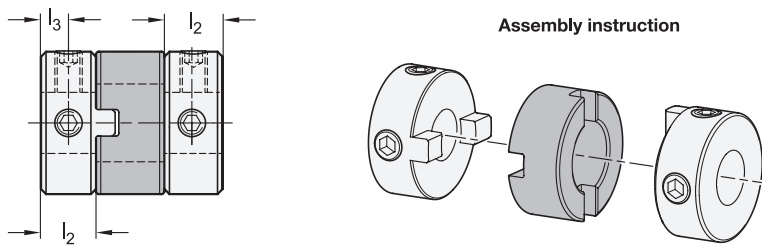

Oldham couplings with inch-inch bore

Dimensions in: inches - *millimeters*

1 d_1	3 $d_2 - d_3 + 0.001$ Bore (in-in) Recommended shaft tolerance -0.001					
0.79 20	1/4-1/4*	1/4-5/16*	1/4-3/8*	5/16-5/16	5/16-3/8	3/8-3/8
1.18 30	3/8-3/8	3/8-1/2	1/2-1/2	-	-	-
1.50 38	1/2-1/2	1/2-5/8	1/2-3/4	5/8-5/8	5/8-3/4	3/4-3/4

*Only available with bore code B

Oldham couplings with metric-metric bore

Dimensions in: millimeters - *inches*

1 d_1	3 $d_2 - d_3$ H8 Bore (mm-mm) Recommended shaft tolerance h7					
8 0.31	2-2	2-3	3-3	-	-	-
12 0.47	4-4	4-5	5-5	-	-	-
15 0.59	4-4	4-5	4-6	5-5	5-6	6-6
20 0.79	6-6	6-8	6-10	8-8	8-10	10-10
30 1.18	8-8	8-10	8-12	10-10	10-12	12-12
38 1.50	12-12	12-15	12-20	15-15	15-20	20-20

Oldham couplings with metric-inch bore

Dimensions in: millimeters - *inches*

1 d_1	3 $d_2 - d_3$ H8 Bore (mm-in) Recommended shaft tolerance h7								
20 0.79	6-1/4*	6-5/16	6-3/8	8-1/4*	8-5/16	8-3/8	10-1/4*	10-5/16	10-3/8
30 1.18	8-3/8	8-1/2	10-3/8	10-1/2	12-3/8	12-1/2	-	-	-
38 1.50	12-1/2	12-5/8	12-3/4	15-1/2	15-5/8	15-3/4	20-1/2	20-5/8	20-3/4

*Only available with bore code B

Dimensions in: millimeters - inches

d ₁	d ₄ Thread	d ₅	l ₁	l ₂ Recommended shaft insertion depth	l ₃	Tightening torque of the screw in Nm ≈
8 0.31	M 2	3.1 0.12	9.6 0.38	2.5 0.10	1.3 0.05	0.3
12 0.47	M 3	5.2 0.20	14.2 0.56	3.9 0.15	2 0.08	0.7
15 0.59	M 3	8.2 0.32	16 0.63	4.4 0.17	2.2 0.09	0.7
20 0.79	M 4	12.2 0.48	21.4 0.84	5.8 0.23	2.9 0.11	1.7
30 1.18	M 4	16.2 0.64	32.5 1.28	10 0.39	5 0.20	1.7
38 1.50	M 5	20.3 0.80	40 1.57	12.1 0.48	6.1 0.24	4

d ₁	Rated torque in Nm*	Max. torque in Nm*	Max. speed (min ⁻¹)	Moment of inertia in kgm ²	Static torsional stiffness in Nm/rad	Max. shaft misalignment	
						Lateral	Angular in °
8 0.31	0.5	1	78,000	7.4 x 10 ⁻⁹	12	0.7 0.028	3
12 0.47	1	2	52,000	5.3 x 10 ⁻⁸	60	1 0.039	3
15 0.59	1.6	3.2	42,000	1.4 x 10 ⁻⁷	80	1 0.039	3
20 0.79	3.2	6.4	31,000	5.7 x 10 ⁻⁷	120	1.2 0.047	3
30 1.18	15	30	21,000	5.4 x 10 ⁻⁶	530	2 0.079	3
38 1.50	28	56	16,000	1.6 x 10 ⁻⁵	1500	2.5 0.098	3

*Load fluctuations are not taken into account

Specification



- Hub
Aluminum **AL**
Anodized finish, natural color
- Spacer
Plastic (Polyacetal POM) **KU**
Temperature resistant up to 176 °F (80 °C)
- Set screws
Steel, blackened finish
- For d₂ / d₃ ≤ 4, one set screw
- For d₂ / d₃ > 4, two set screws
- Temperature range from: -4 °F up to +176 °F
(-20 °C up to +80 °C)
- Keyways WN / DIN 6885
→ Standard Parts Handbook page 2039 / 2040
- ISO Fundamental Tolerances
→ Standard Parts Handbook page 2129
- Plastic Characteristics
→ Standard Parts Handbook page 2135
- RoHS compliant

Information

Oldham couplings GN 2243 can compensate for large lateral shaft misalignments while transmitting high torques. As a result, they are used in applications with a focus on pure torque and power transmission associated with high lateral shaft misalignments.

The use of set screws for clamping and the simple plug-in installation make oldham couplings very easy to assemble. They are suitable for a diverse range of applications and are used in general machine construction in packaging machines and pumps.

With the bore code K, the keyway is always integrated into both bores d₂ and d₃.

see also...

- *Elastomer Jaw Couplings GN 2241 (Hub with Set Screw)* → page 11
- *Oldham Couplings GN 2242 (with Clamping Hub)* → page 14
- *Installation Information on Couplings* → page 24
- *Technical Information on Couplings* → page 26

How to order	
	1 Outside diameter d ₁
	2 Bore code
	3 Bore d ₂ -d ₃
	4 Material (Hub)
	5 Material (Spacer)

GN 2243-38-B1/2-1/2-AL-KU

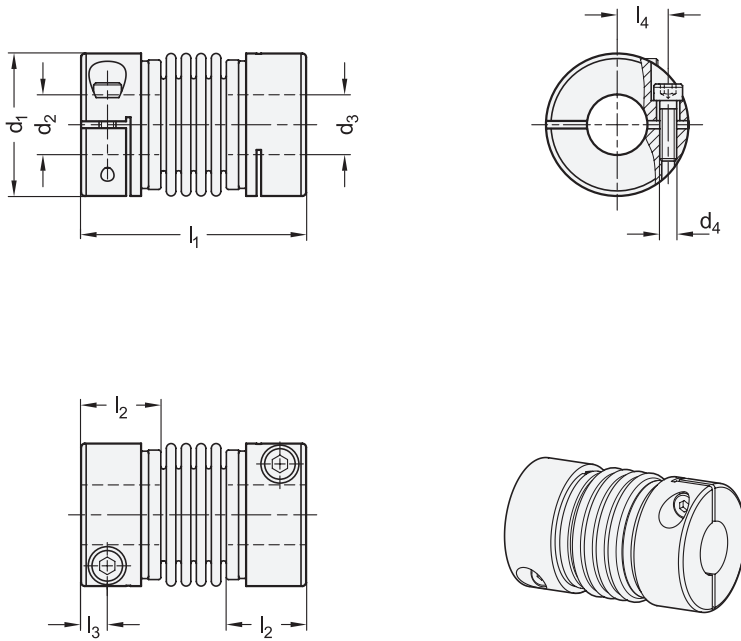

2 Bore code

B Without keyway

Bellows couplings with inch-inch bore

1 **3**

Dimensions in: inches - *millimeters*

d₁	d₂ - d₃ +0.001 Bore (in-in) Recommended shaft tolerance -0.001														
0.75 19	3/16-3/16	3/16-1/4	1/4-1/4	-	-	-	-	-	-	-	-	-	-	-	-
1.06 27	1/4-1/4	1/4-3/8	1/4-1/2	3/8-3/8	3/8-1/2	1/2-1/2	-	-	-	-	-	-	-	-	-
1.26 32	1/4-1/4	1/4-3/8	1/4-1/2	1/4-5/8	3/8-3/8	3/8-1/2	3/8-5/8	1/2-1/2	1/2-5/8	5/8-5/8	-	-	-	-	-
1.57 40	3/8-3/8	3/8-1/2	3/8-5/8	3/8-3/4	3/8-7/8	1/2-1/2	1/2-5/8	1/2-3/4	1/2-7/8	5/8-5/8	5/8-3/4	5/8-7/8	3/4-3/4	3/4-7/8	7/8-7/8

Bellows couplings with metric-metric bore

1 **3**

Dimensions in: millimeters - *inches*

d₁	d₂ - d₃ H8 Bore (mm-mm) Recommended shaft tolerance h7														
19 0.75	5-5	5-6	5-8	6-6	6-8	8-8	-	-	-	-	-	-	-	-	-
27 1.06	6-6	6-8	6-10	8-8	8-10	10-10	-	-	-	-	-	-	-	-	-
32 1.26	10-10	10-12	10-14	12-12	12-14	14-14	-	-	-	-	-	-	-	-	-
40 1.57	12-12	12-15	12-19	15-15	15-19	19-19	-	-	-	-	-	-	-	-	-

Bellows couplings with metric-inch bore

1 **3**

Dimensions in: millimeters - *inches*

d₁	d₂ - d₃ H8 Bore (mm-in) Recommended shaft tolerance h7														
19 0.75	5-3/16	5-1/4	6-3/16	6-1/4	8-3/16	8-1/4	-	-	-	-	-	-	-	-	-
27 1.06	6-1/4	6-3/8	6-1/2	8-1/4	8-3/8	8-1/2	10-1/4	10-3/8	10-1/2	-	-	-	-	-	-
32 1.26	10-1/4	10-3/8	10-1/2	10-5/8	12-1/4	12-3/8	12-1/2	12-5/8	14-1/4	14-3/8	14-1/2	14-5/8	-	-	-
40 1.57	12-3/8	12-1/2	12-5/8	12-3/4	12-7/8	15-3/8	15-1/2	15-5/8	15-3/4	15-7/8	19-3/8	19-1/2	19-5/8	19-3/4	19-7/8

Dimensions in: millimeters - inches

d ₁	d ₄ Thread	l ₁	l ₂ Recommended shaft insertion depth	l ₃	l ₄	Tightening torque of the screw in Nm ≈
19 0.75	M 2	30 1.18	10.5 0.41	3 0.12	6.8 0.27	0.5
27 1.06	M 2.5	35 1.38	12.5 0.49	3.5 0.14	10.3 0.41	0.9
32 1.26	M 3	46 1.81	15.5 0.61	4.3 0.17	12 0.47	1.5
40 1.57	M 4	51 2.01	16 0.63	5 0.20	15 0.59	3.5

d ₁	Rated torque in Nm	Max. speed (min ⁻¹)	Moment of inertia in kgm ²	Static torsional stiffness in Nm/rad	Max. shaft misalignment		Angular in °
					Lateral	Axial	
19 0.75	1.5	33,000	8.6 x 10 ⁻⁷	170	0.15 0.006	± 0.5 ±0.020	1.5
27 1.06	2.3	23,000	3.6 x 10 ⁻⁶	800	0.15 0.006	± 0.5 ±0.020	1.5
32 1.26	4.5	19,000	1.1 x 10 ⁻⁵	1600	0.2 0.008	± 0.7 ±0.028	1.5
40 1.57	10	15,000	2.8 x 10 ⁻⁵	2700	0.2 0.008	± 1 ±0.039	1.5

Specification



- Hub
Aluminum **AL**
Anodized finish, natural color
- Bellows
Stainless steel **NI**
AISI 304
- Socket cap screws DIN 912
Steel, blackened finish
- Crimp ring
Brass
- Temperature resistant up to 248 °F (120 °C)
- ISO Fundamental Tolerances
→ Standard Parts Handbook page 2129
- Stainless Steel Characteristics
→ Standard Parts Handbook page 2143
- RoHS compliant

On request

- Bore with keyway

Information

Bellows couplings GN 2244 transmit angle positions and torques with extreme precision and zero backlash. The metal bellows also reliably compensates for shaft misalignments and runout tolerances. The clamping hubs make bellows couplings very easy to install.

They are used in applications where precise position and movement transmission is required, such as in the servo drive systems of machine tools and in industrial robots.

see also...

- *Elastomer Jaw Couplings GN 2240 (with Clamping Hub)* → page 8
- *Beam Couplings GN 2246* → page 20
- *Installation Information on Couplings* → page 24
- *Technical Information on Couplings* → page 26

How to order	
1	Outside diameter d ₁
2	Bore code
3	Bore d ₂ -d ₃
4	Material (Hub)
5	Material (Bellows)







GN 2244 - 19 - B3/16 - 1/4 - AL - NI

GN 2246

Aluminum / Stainless Steel

Beam Couplings

with Clamping Hub



JWWINCO
A Ganter Company

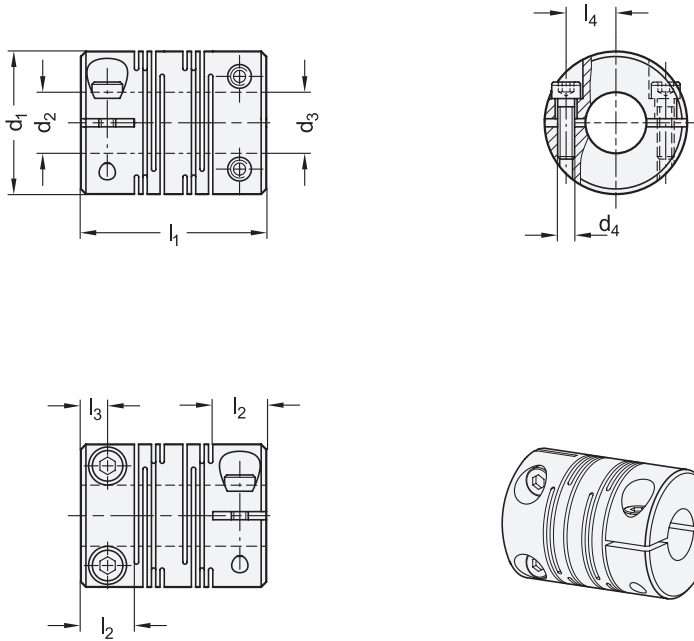

SS Stainless Steel

2 Bore code

B Without keyway

Bellows couplings with metric-metric bore

Dimensions in: millimeters - inches

1 d_1	3 $d_2 - d_3$ H8 Bore (mm-mm) Recommended shaft tolerance h7					
12 0.47	4-4	4-5	5-5	-	-	-
16 0.63	5-5	5-6	6-6	-	-	-
20 0.79	5-5	5-6	5-8	6-6	6-8	8-8
25 0.98	6-6	6-8	6-10	8-8	8-10	10-10
32 1.26	10-10	10-12	12-12	-	-	-

Bellows couplings with metric-inch bore

Dimensions in: millimeters - inches

1 d_1	3 $d_2 - d_3$ H8 Bore (mm-in) Recommended shaft tolerance h7				
20 0.79	5-1/4	6-1/4	8-1/4	-	-
25 0.98	6-1/4	8-1/4	8-3/8	10-1/4	10-3/8
32 1.26	10-3/8	12-3/8	-	-	-

d_1	d_4 Thread	l_1	l_2 Recommended shaft insertion depth	l_3	l_4	Tightening torque of the screw in Nm \approx
12 0.47	M 2	18.5 0.73	5 0.20	2.5 0.10	4 0.16	0.5
16 0.63	M 2.5	23 0.91	6.5 0.26	3.25 0.13	5 0.20	1
20 0.79	M 2.5	26 1.02	7.5 0.30	3.75 0.15	6.5 0.26	1
25 0.98	M 3	31 1.22	8.5 0.33	4.25 0.17	9 0.35	1.5
32 1.26	M 4	41 1.61	12 0.47	6 0.24	11 0.43	2.5

Dimensions in: millimeters - inches

Aluminum d ₁	Rated torque in Nm	Max. speed (min ⁻¹)	Moment of inertia in kgm ²	Static torsional stiffness in Nm/rad	Max. shaft misalignment		
					Lateral	Axial	Angular in °
12 0.47	0.4	52,000	7.8 x 10 ⁻⁸	45	0.1 0.004	± 0.3 ±0.012	2
16 0.63	0.5	39,000	3.4 x 10 ⁻⁷	80	0.1 0.004	± 0.4 ±0.016	2
20 0.79	1	31,000	9.1 x 10 ⁻⁷	170	0.1 0.004	± 0.4 ±0.016	2
25 0.98	2	25,000	2.6 x 10 ⁻⁶	380	0.15 0.006	± 0.5 ±0.020	2
32 1.26	4	19,000	9.7 x 10 ⁻⁶	500	0.15 0.006	± 0.5 ±0.020	2

Stainless Steel d ₁	Rated torque in Nm	Max. speed (min ⁻¹)	Moment of inertia in kgm ²	Static torsional stiffness in Nm/rad	Max. shaft misalignment		
					Lateral	Axial	Angular in °
12 0.47	0.3	52,000	2.2 x 10 ⁻⁷	64	0.1 0.004	± 0.2 ±0.079	2
16 0.63	0.5	39,000	9.0 x 10 ⁻⁷	85	0.1 0.004	± 0.3 ±0.012	2
20 0.79	1	31,000	2.5 x 10 ⁻⁶	250	0.1 0.004	± 0.3 ±0.012	2
25 0.98	2	25,000	7.1 x 10 ⁻⁶	330	0.15 0.006	± 0.4 ±0.016	2
32 1.26	3.5	19,000	2.7 x 10 ⁻⁵	850	0.15 0.006	± 0.5 ±0.020	2

Specification



- Aluminum **AL**
 - Anodized finish, natural color
 - Temperature resistant up to 302 °F (150 °C)
 - Socket cap screws DIN 912 Steel, blackened finish
- Stainless steel AISI 303 **NI**
 - Temperature resistant up to 392 °F (200 °C)
 - Socket cap screws DIN 912 Stainless steel AISI 304Cu
- ISO Fundamental Tolerances → Standard Parts Handbook page 2129
- Stainless Steel Characteristics → Standard Parts Handbook page 2143
- RoHS compliant

On request

- Inch bores
- Bore with keyway

Information

Beam couplings GN 2246 transmit angle positions and torques with extreme precision and no backlash. They are manufactured of a single piece and offer high torsional stiffness thanks to the alternating slits. The clamping hubs make beam couplings very easy to assemble.

They are used in applications where precise position and movement transmission is required, such as in the drive systems of position measuring systems and in test benches.

The Stainless Steel version can also be used in environments requiring high corrosion resistance, such as in medical technology (CAT scanners) and food-processing equipment (confectionary machines).

see also...

- Elastomer Jaw Couplings GN 2240 (with Clamping Hub) → page 8
- Bellows Couplings GN 2244 → page 18
- Installation Information on Couplings → page 24
- Technical Information on Couplings → page 26

<p>How to order</p> <p>1 2 3 4</p> <p>GN 2246 - 32 - B10 - 3/8 - NI</p>	1	Outside diameter d ₁
	2	Bore code
	3	Bore d ₂ -d ₃
	5	Material

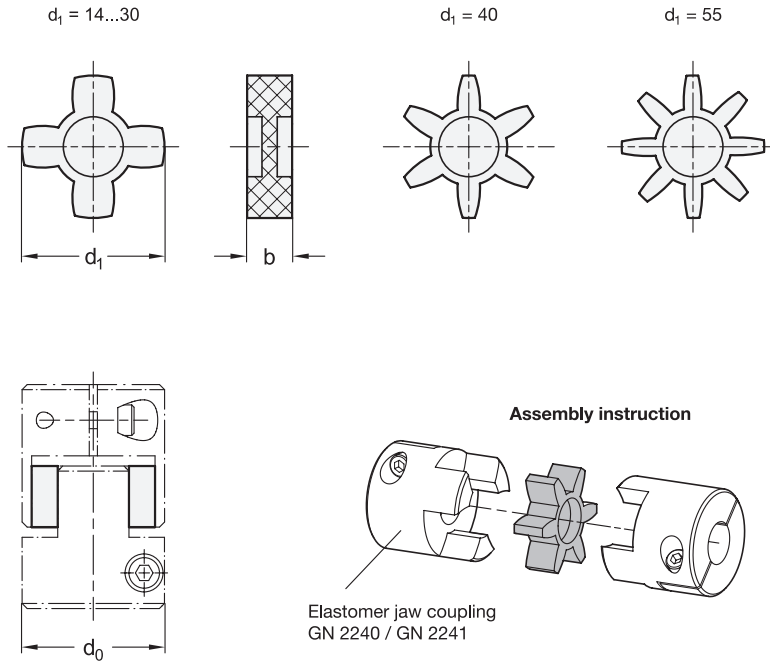

Metric table

Dimensions in: millimeters - inches

d₀ Coupling Ø GN 2240 / GN 2241	d₁	b	Number of teeth
14 0.55	14 0.55	6 0.24	4
20 0.79	20 0.79	8 0.31	4
30 1.18	30 1.18	10 0.39	4
40 1.57	40 1.57	12 0.47	6
55 2.17	55 2.17	14 0.55	8

Specification

- Thermoplastic Polyurethane (TPU)
Temperature resistant up to 140 °F (60 °C)
- Hardness
80 shore A, blue
92 shore A, white
98 shore A, red
- *Elastomer Characteristics*
→ *Standard Parts Handbook page 2135*
- [RoHS compliant](#)



BS
WS
RS

Information

- Coupling spiders GN 2240.1 are intended as replacement parts or for adjusting GN 2240 / GN 2241 elastomer jaw couplings.
- The choice of three coupling spiders with different hardness values allows the properties of the coupling to be optimally matched to the specific requirements.
- see also...
- *Elastomer Jaw Couplings GN 2240 (with Clamping Hub)* → page 8
 - *Elastomer Jaw Couplings GN 2241 (with Grub Screw)* → page 11

How to order	1 Diameter d ₁
	2 Hardness

GN 2240.1-14-BS

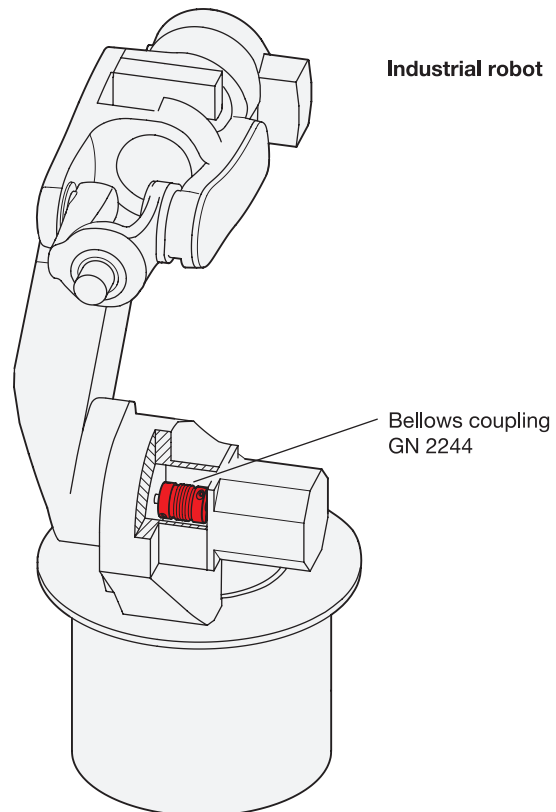
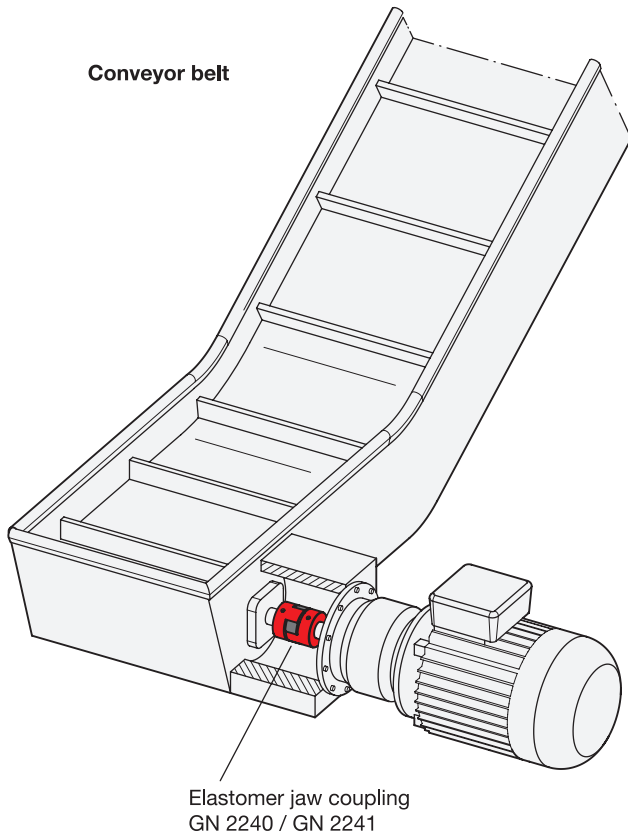

Shaft-hub fastening

The right type of fastening must be selected to ensure simple and reliable mounting of the coupling hub on the shaft. The following shaft-hub fastening types are available:

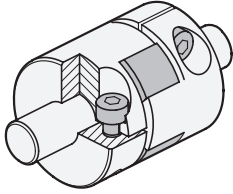
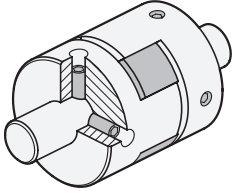
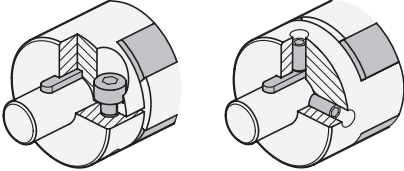
Clamping hub	
	<p>The fastening with clamping hubs is entirely non-positive by reducing the slit height using socket head screws.</p> <p>In this type, the coupling hub is fastened simply and securely with a high clamping force, without damaging the surface of the shafts.</p>
Grub screw	
	<p>When used for fastening, grub screws are inserted radially to create a positive and non-positive connection to the shaft surface.</p> <p>Alignment holes bored into the mounting diameter allow the coupling hub to be positioned precisely. At the same time, this prevents damage to the clamping point.</p>
Combination with keyway	
	<p>The combination of grub screw or clamping hub fastening with feather keys prevents slipping due to torque while ensuring precise angular positioning of the shafts.</p> <p>This type of fastening also provides for maximum torque transmission.</p>

Shaft insertion depth

For correct fastening of the coupling hubs, the shaft must be installed according to the recommended shaft insertion depth l_2 . The shaft insertion depth l_2 is specified in the standard sheet of the respective coupling.

If the insertion depth is too low, the shaft could slip out of the coupling, or the clamping hub could break. If the shaft is inserted too far, this can cause interference within the coupling, leading to damage.

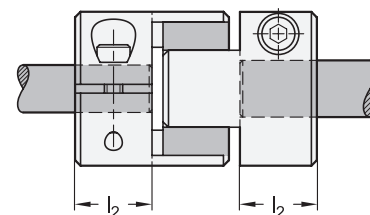

Alignment adjustment

Like all mechanical parts, shafts are subjected to manufacturing and assembly tolerances that generally cannot be entirely eliminated even with extensive technical measures. Couplings can compensate for the resulting misalignments while still ensuring transmission of the necessary torque.

However, if the misalignments exceed the permissible values, this results in vibrations that can quickly shorten the service life of the coupling. The actual shaft misalignment may, therefore, never be larger than the specified permissible values.

The permissible shaft misalignment values given in the standard sheet take into account only the lateral, angular or axial misalignment. In the event of combined misalignments consisting of two or more errors, each permissible value is reduced to half the value specified in the standard sheet.

In general, it is recommended to limit misalignments to no more than one third of the permissible value in the standard sheet. This is because shaft misalignment occurs not only during assembly. It often develops during operation as the result of vibrations, thermal expansion or bearing wear.

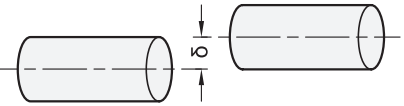
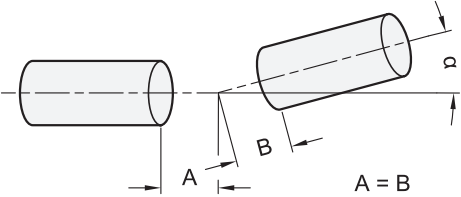
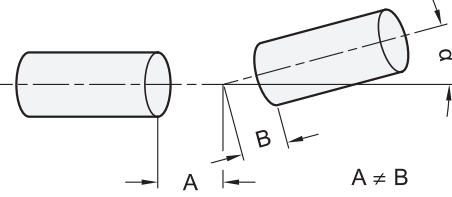
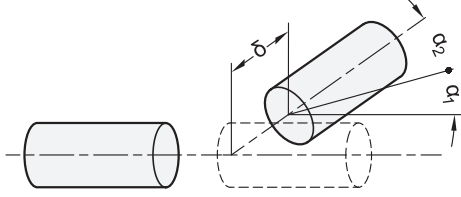
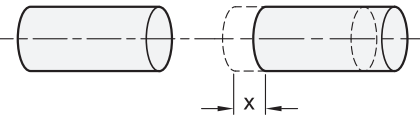
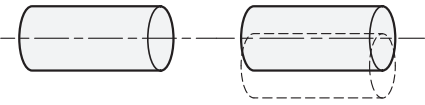
lateral	angular - symmetrical
	
angular - asymmetrical	lateral and angular
	
axial (axial motion)	Runout
	

Temperature correction factors

If the ambient temperature is greater than 86 °F (30 °C), the rated torque and the maximum torque must be adjusted using the temperature correction factors.

Ambient temperature	Temperature correction factor	
	for GN 2240 / GN 2241	for GN 2242 / GN 2243
-4 °F up to +86 °F (-20 °C up to +30 °C)	1	1
+86 °F up to +104 °F (+30 °C up to +40 °C)	0.8	0.8
+104 °F up to +140 °F (+40 °C up to +60 °C)	0.7	0.7
+140 °F up to +176 °F (+60 °C up to +80 °C)	-	0.55

Static torsional stiffness and temperature

The diagrams show the change in static torsional stiffness within the permissible operating temperature range, under the assumption that the static torsional stiffness at 68 °F (20 °C) is 100 percent. The torsional stiffness of the couplings decreases with increasing temperature.

GN 2240 / GN 2241

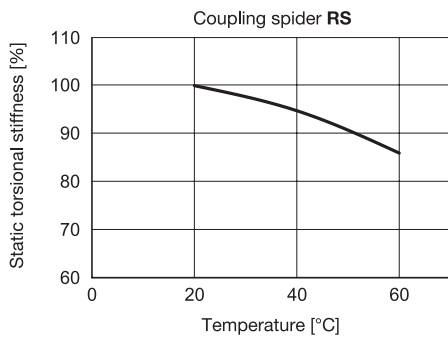
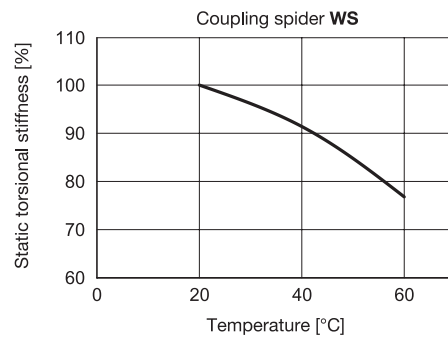
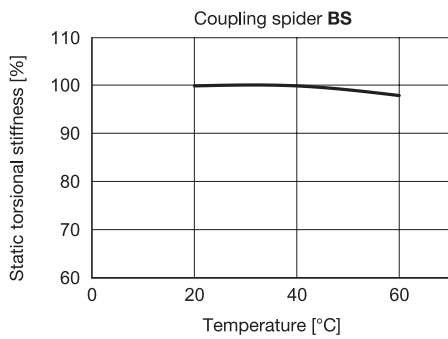

GN 2242 / GN 2243

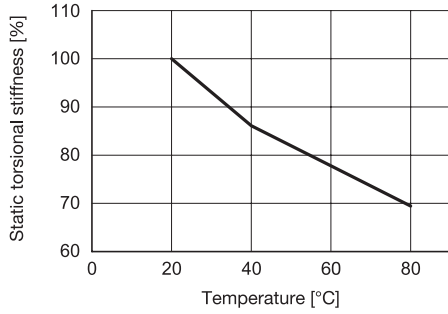

GN 2244

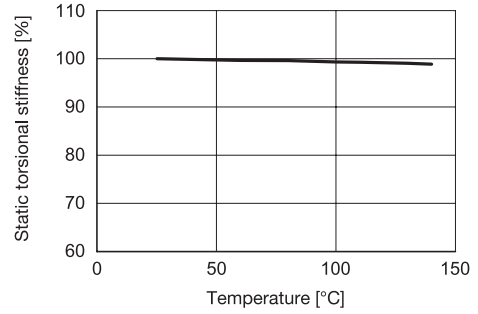

GN 2246

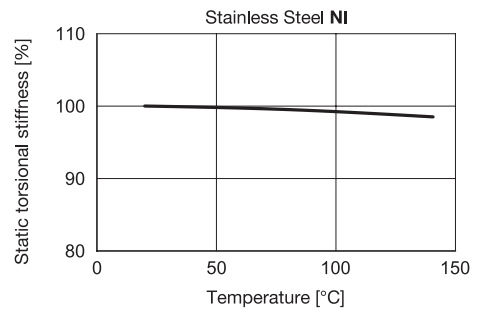
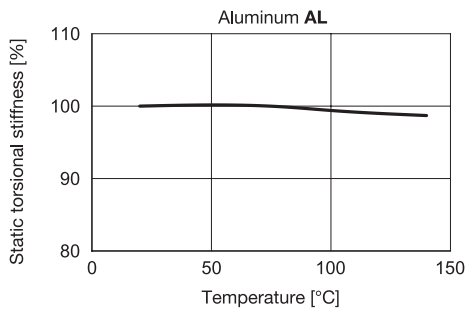

J.W. Winco, Inc.*

2815 South Calhoun Road
New Berlin, WI 53151
USA

Phone +1-800-877-8351

E-Mail sales@jwwinco.com

*ISO 9001 certified

J.W. Winco Canada, Inc.

300 Trowers Rd, Unit 11,
Woodbridge, ON L4L 5Z9
Canada

Phone +1-800-397-6993

E-Mail sales@jwwinco.ca

JW Winco México, S.A. de C.V.

Parque Industrial Makro, Bodega 10
Santa Catarina, N.L. 66359
México

Phone +52(81)2721-4021

E-Mail ventas@jwwinco.mx

www.jwwinco.com