

**3 Installation (front view)**

- AN** On the chamfer, above
- AR** On the chamfer, below
- FN** In the front, above
- FR** In the front, below

**4 Type**

- R** Numbers increasing clockwise
- L** Numbers increasing counter-clockwise

**Inch & Metric table**

Bore d H7		Counter			
Inch	Metric		Indication after 1 spindle revolution	Corresponds to thread pitch in millimeters	Max. revolutions per minute
B 1/2	B 14	0.050	0050	0.05	500
B 1/2	B 14	00.10	0010	0.1	1500
B 1/2	B 14	00.20	0020	0.2	1250
B 1/2	B 14	00.50	0050	0.5	500
B 1/2	B 14	01.00	0100	1	250
B 1/2	B 14	001.0	0010	1	1500
B 1/2	B 14	001.25	00125	1.25	1500
B 1/2	B 14	001.5	0015	1.5	1500
B 1/2	B 14	002.0	0020	2	1250
B 1/2	B 14	002.5	0025	2.5	1000
B 1/2	B 14*	003.0	0030	3	830
B 1/2	B 14**	004.0	0040	4	625
B 1/2	B 14	005.0	0050	5	500
B 1/2	B 14	006.0	0060	6	415
B 1/2	B 14	008.0	0080	8	315
B 1/2	B 14	010.0	0100	10	250

\* Suitable for linear actuators GN 291 and GN 292 Ø 18 mm \*\* Suitable for linear actuators GN 291, GN 292 and GN 293 Ø 30 mm

**Specification**

- Housing  
Plastic  
Technopolymer (Polyamide PA)
  - Orange, RAL 2004 ● **OR**
  - Gray, RAL 7035 ● **GR**
  - Black-gray, RAL 7021 ● **SG**
  - Temperature resistant up to 176 °F (80 °C)
  - Oil and solvent resistant
- Counter
  - White numbers
  - Black number wheels integers
  - Red decimals with additional scale
- Shaft receptacle  
Steel, blackened finish
- Set screw DIN 916  
With internal hex and serrated point
- ISO Fundamental Tolerances → page 2129
- Plastic Characteristics → page 2135
- RoHS compliant

**Information**

EN 954 digital position indicators have a direct coupled drive with digital indications. The two housing component parts are ultrasonically welded, thus making the housing is especially sturdy and compact. The foam rubber seal at the back of the indicator housing prevents the transmission of vibration between the machine and the counter mechanism and also acts as a seal. Special attention was paid to the positioning of the readout window. The numbers are easily legible and are even enlarged by the magnifying effect of the sight glass.

**On request**

- Position indicators EN 954 with locking lever to prevent accidental change

<p>How to order</p> <p>1 2 3 4 5</p> <p><b>EN 954-B14-00.50-FN-L-OR</b></p>	1 Bore d
	2 Counter
	3 Installation (front view)
	4 Type
	5 Color

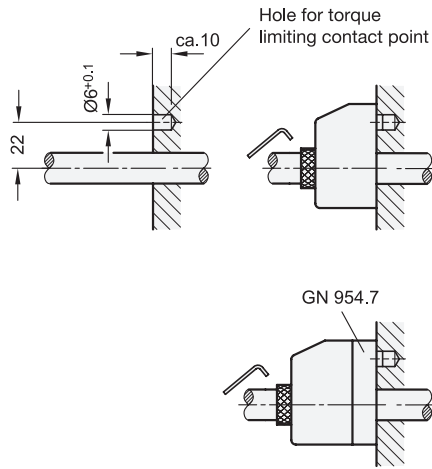

**Installation instructions**

Before installation of the position indicator a bore for the torque limiting contact point is to be placed (see left).

With the **EN 952.1 mounting adapters** the hollow shaft (with bore 20 H7) of the position indicator can be adapted to fit the spindle. → page 388

The mounting of the position indicator is via the torque limiting contact point which is connected to the hollow spindle and secured with a set screw.

Before completing the installation, turn the spindle to the starting point (0 position) and zero the position indicator.

With **GN 954.7 clamping plates** spindles can be clamped and secured after adjusting. → page XYZ

**EN 954.1 | Spacer Plate**

Technopolymer Plastic, for Digital Position Indicators EN 954 / EN 954.2

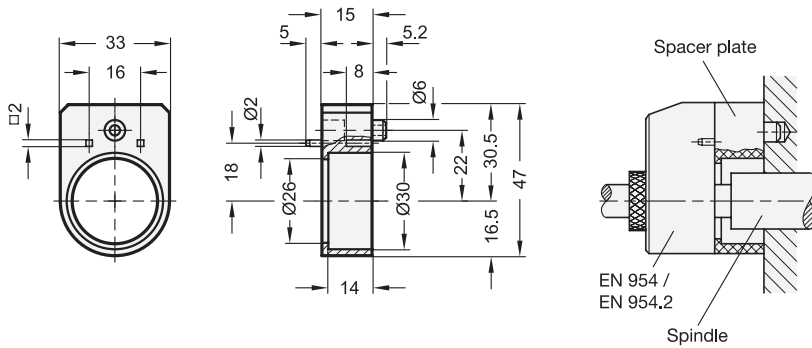

**Specification**

- Plastic  
Technopolymer (Polyamide PA)  
Black, matte finish
- RoHS compliant

**Information**

The spacer plate EN 954.1 in combination with the digital position indicators EN 954 / EN 954.2 are used to bridge the shaft shoulders, set collars and so on.

The square bore holes are used for the machine-side fastening with e.g. socket button head self-tapping screws in accordance with DIN ISO 7049.

see also...

- Digital Position Indicators EN 954 (Steel Shaft Receptacle) → page XYZ
- Digital Position Indicators EN 954.2 (Stainless Steel Shaft Receptacle) → page XYZ

How to order

**EN 954.1**

1.1  
1.2  
1.3  
1.4  
2.1  
2.2  
2.3  
2.4