

Operating principle

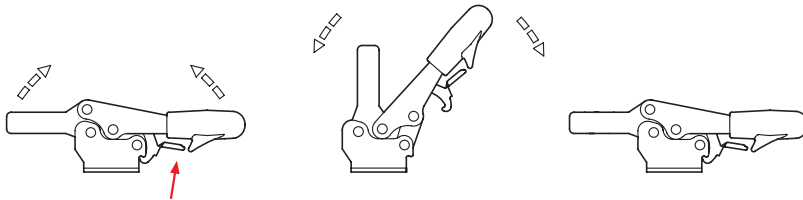

2 Type

- UL** Clamping arm extended, with slotted hole and with two flanged washers
- ULC** Clamping arm extended, with slotted hole, two flanged washers and GN 708.1 spindle assembly

Specification

- Toggle clamp
 - Case-hardened steel C10
 - Zinc plated, blue passivated finish
 - Tempered bearing pins
 - Case-hardened bearing rivets
- All moving parts lubricated with special grease
- Hand grip
 - High quality, oil resistant red plastic
- Spindle assembly GN 708.1, Type A
 - page 858
 - Steel, zinc plated, blue passivated finish
 - Rubber tip 85 shore A
- **RoHS compliant**

Accessory

- Spindle assemblies → starting from page 856
- Clamp mounts GN 801 (for type UL)
 - www.jwwinco.com
- Clamping arm extenders GN 801.1 (for type UL)
 - page 860
- Clamping arm extenders GN 801.2 (for type UL)
 - page 861

Information

GN 820.3 extended arm horizontal acting toggle clamps have a safety function whereby, during closing, a spring loaded safety hook latch ensures a secure locking connection. It prevents the inadvertent unlocking of the clamp due to vibrations or an accidental attempt of loosening / opening of the clamp. To open and release the clamp, pull up on the finger grip to disengage the safety hook latch mechanism (one hand operation).

They work according to the toggle principle: lever and clamping bar move in the opposite direction. They require less space for the clamping action.

Extended arm horizontal acting toggle clamps in the U-bar version with two flanged washers (Type UL) can accommodate an application specific clamping screw. A spindle assembly with neoprene rubber tip is also included for Type ULC.

see also...

- *General Information on Toggle Clamps* → page 756
- *Extended Arm Horizontal Acting Toggle Clamps GN 820.4* → page 784

How to order

GN820.3-230-UL

1 Size

2 Type

Universal table



Dimensions in: millimeters - inches

Size	F _H Holding capacity	a ≈	b ₁	b ₂	b ₃	d ₁	d ₂	h ₁ ≈	h ₂	h ₃	h ₄	h ₅ max.
130	600 N 135 lbf	67.5 2.66	36 1.42	40 1.57	6.3 0.25	M 6	5.6 0.22	51 2.01	30.5 1.20	16 0.63	25.5 1.00	14 0.55
230	1100 N 247 lbf	71.5 2.81	44 1.73	44 1.73	8.2 0.32	M 8	6.6 0.26	61.5 2.42	36.5 1.44	18 0.71	30 1.18	12.5 0.49

Size	l ₁ ≈	l ₂ ≈	l ₃ ≈	l ₄	m ₁	m ₂	m ₃	r	s	w Adjustable range
130	250 9.84	171 6.73	133 5.24	55 2.17	26 1.02	22.4 0.88	28.4 1.12	141 5.55	2.5 0.10	17.5 0.69
230	283 11.14	196 7.72	152.5 6.00	68 2.68	26 1.02	26 1.02	31.5 1.24	158.5 6.24	3 0.12	20 0.79

Type UL

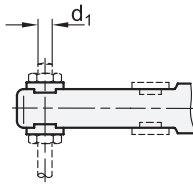

Type ULC

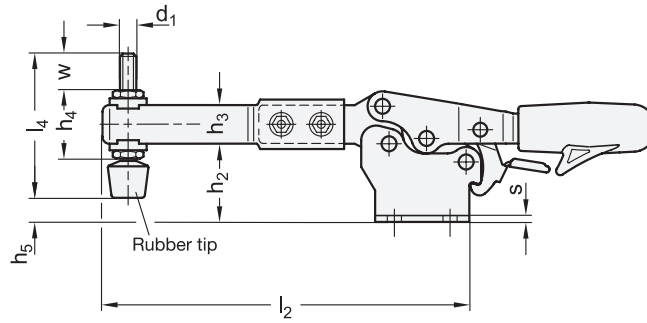

Flanged washers
movable

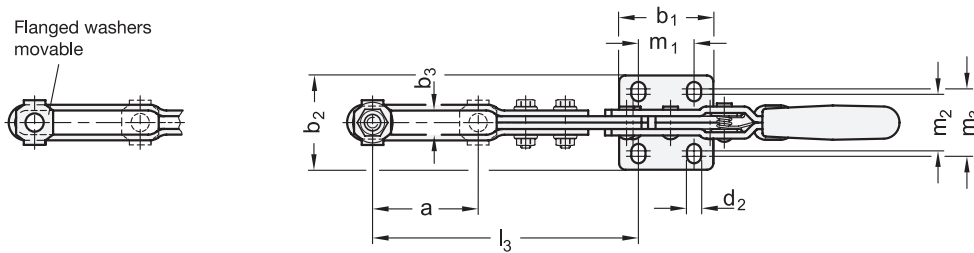

1.1
1.2
1.3
1.4
2.1
2.2
2.3
2.4

