

Double Tube Linear Actuators

Technical Description

GN 491

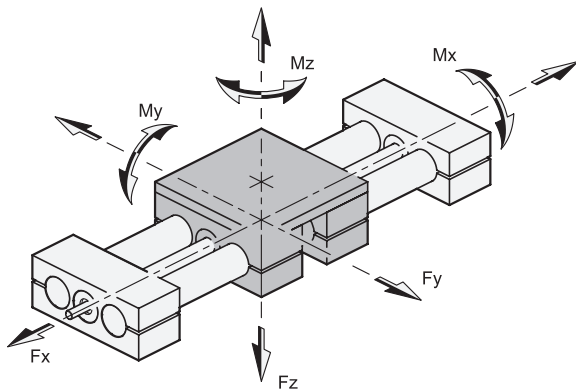

GN 492

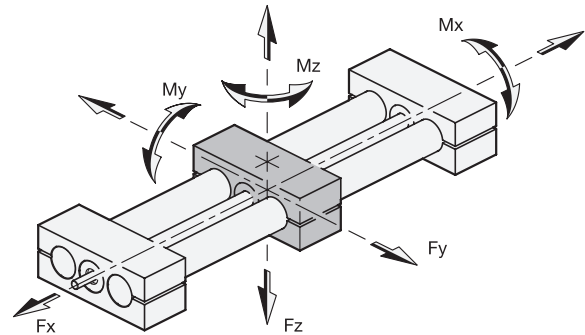

Metric table

Dimensions in: millimeters - inches

d GN 491	Fx	Fy for length l =			Fz for length l =			Mx in Nm	My in Nm	Mz in Nm
		500	1000	1500	500	1000	1500			
18 0.71	425 N 95.54 lbf	215 N 48.33 lbf	110 N 24.73 lbf	550 N 124 lbf	600 N 135 lbf	350 N 78.68 lbf	150 N 33.72 lbf	22	35	40
30 1.18	850 N 191 lbf	1100 N 247 lbf	900 N 202 lbf	550 N 124 lbf	600 N 135 lbf	350 N 78.68 lbf	150 N 33.72 lbf	100	100	100
40 1.57	1100 N 247 lbf	3700 N 832 lbf	2800 N 629 lbf	1400 N 315 lbf	2100 N 472 lbf	600 N 135 lbf	180 N 40.47 lbf	150	140	170
50 1.97	1900 N 427 lbf	3850 N 866 lbf	2400 N 540 lbf	2100 N 472 lbf	3100 N 697 lbf	700 N 157 lbf	200 N 44.96 lbf	180	220	290
60 2.36	2700 N 607 lbf	6900 N 1551 lbf	5700 N 1282 lbf	5100 N 1147 lbf	6300 N 1416 lbf	2800 N 629 lbf	360 N 80.93 lbf	320	350	500

d GN 492	Fx	Fy for length l =			Fz for length l =			Mx in Nm	My in Nm	Mz in Nm
		500	1000	1500	500	1000	1500			
18 0.71	425 N 95.54 lbf	290 N 65.19 lbf	180 N 40.47 lbf	800 N 180 lbf	700 N 157 lbf	550 N 124 lbf	250 N 56.20 lbf	42	50	75
30 1.18	850 N 191 lbf	1550 N 348 lbf	1300 N 292 lbf	800 N 180 lbf	700 N 157 lbf	550 N 124 lbf	250 N 56.20 lbf	150	150	200
40 1.57	1100 N 247 lbf	6400 N 1439 lbf	3400 N 764 lbf	1900 N 427 lbf	2400 N 540 lbf	750 N 169 lbf	290 N 65.19 lbf	180	210	260
50 1.97	1900 N 427 lbf	7500 N 1686 lbf	5100 N 1147 lbf	2700 N 607 lbf	3400 N 764 lbf	850 N 191 lbf	340 N 76.44 lbf	250	350	530
60 2.36	2700 N 607 lbf	11500 N 2585 lbf	9500 N 2136 lbf	8200 N 1843 lbf	7500 N 1686 lbf	3100 N 697 lbf	610 N 137 lbf	550	650	980

The specified forces Fy and Fz cause a flexure of the guide tube of approx. 0.5 mm.

Description

The slider is moved via a trapezoidal thread spindle with ball bearings and a lead nut. It is guided by two parallel, chrome plated tubes, resulting in a high load capacity and allowing high bending moments to be compensated by the linear actuator.

For GN 492 double tube linear actuators, two sliders are connected by an adapter plate, which extends the range of applications.

These double tube linear actuators are designed for manual operation, e.g. with a handwheel. With appropriate lubrication, they can also be operated at spindle speeds of up to 250 RPM.

The positioning accuracy is 0.2 mm / 300 mm stroke; the backlash is max. 0.1 mm.

Digital position indicators (EN 953 / EN 954 / EN 9053 / EN 9054 → page 372 / 374 / 378 / 380) may be attached to measure the movement or the position. The required extension of the shaft journal is enabled by GN 491.1 installation kits → page 1977.

Get further information on the standard pages of GN 491 / GN 492 → page 1970 / 1974.