

3.1
3.2
3.3
3.4
3.5
3.6
3.7
3.8
3.9
3.10

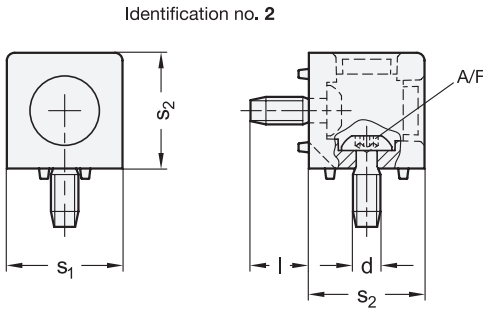

Application examples

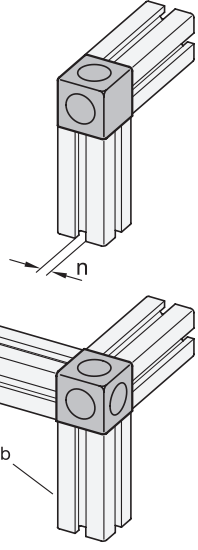

Metric



- 4 Identification no.**
- 2 Connecting 2 profiles
 - 3 Connecting 3 profiles
- 5 Type**
- C With fastening set

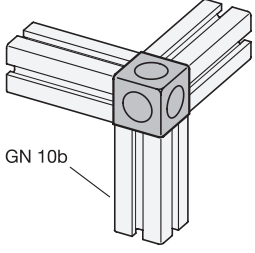
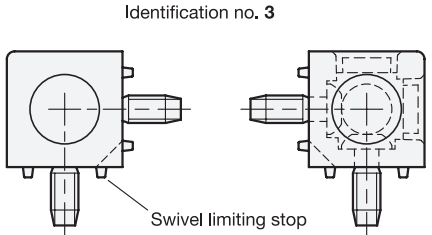

Metric table

Dimensions in: millimeters / inches

1 s ₁	2 s ₂	3 n	d Self-forming thread	Length l ≈	A/F	Tightening torque in Nm
30 1.18	30 1.18	8 0.31	S 8	21 0.83	5	25
45 1.77	45 1.77	10 0.39	S 12	24 0.94	T50	35

Specification

Housing	Aluminum, plain finish	AB
Screws	Steel, zinc plated, blue passivated finish	SZ
Cover caps	Plastic, Polyamide (PA)	
	Black	● S
RoHS		

Cube connectors GN 33b fasten two or three aluminum profiles together on their end faces, at right angles and with anti-twist protection. Machining of the profile is not necessary. The self-forming thread of the screws should be lubricated to facilitate assembly. The end faces of the aluminum profiles are covered by the cube connectors, which ensures a visually appealing appearance. If panels are used in the slot, they must be given a suitable corner chamfer.

see also...

GN 10b Aluminum Profiles (Profile Type Light)	QVX
GN 10b Aluminum Profiles (Profile Type Heavy)	QVX

Technical Information

Plastic Characteristics	QVX
-------------------------	-----

How to order

1	Width s ₁
2	Height s ₂
3	Slot width n
4	Identification no.
5	Type
6	Finish (Housing)
7	Material / Finish (Screws)
8	Color of the cover cap

GN 33b-454510-2-C-ABSZ S