

Mounting holes - Outer slide

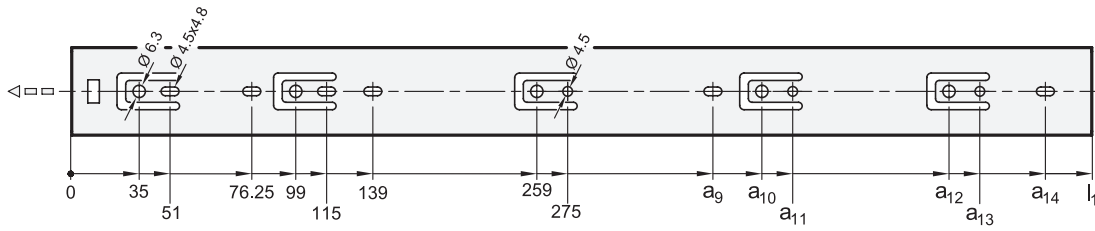

Metric table



Dimensions in: millimeters - inches

l_1	a_9	a_{10}	a_{11}	a_{12}	a_{13}	a_{14}
300 11.81	-	-	-	-	-	-
350 13.78	309 12.17	-	-	-	-	-
400 15.75	-	323 12.72	339 13.35	-	-	373 14.69
450 17.72	361.5 14.23	387 15.24	403 15.87	-	-	-
500 19.69	361.5 14.23	387 15.24	403 15.87	451 17.76	467 18.39	-
550 21.65	361.5 14.23	387 15.24	403 15.87	451 17.76	467 18.39	501 19.72
600 23.62	361.5 14.23	387 15.24	403 15.87	515 20.28	531 20.91	565 22.24

Mounting holes - Inner slide

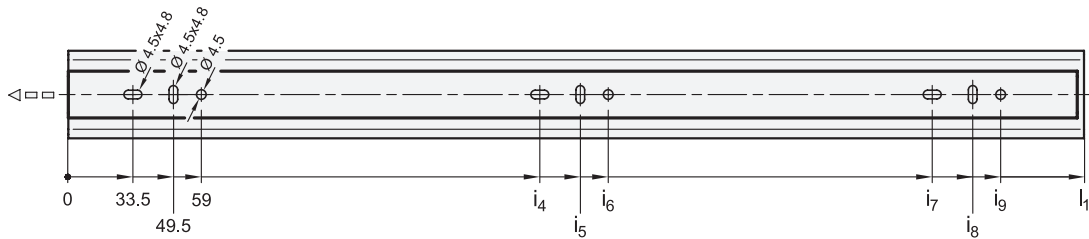

Metric table



Dimensions in: millimeters - inches

l_1	i_4	i_5	i_6	i_7	i_8	i_9
300 11.81	129.5 5.10	145.5 5.73	155 6.10	257.5 10.14	273.5 10.77	283 11.14
350 13.78	161.5 6.36	177.5 6.99	187 7.36	289.5 11.40	305.5 12.03	315 12.40
400 15.75	193.5 7.62	209.5 8.25	219 8.62	353.5 13.92	369.5 14.55	379 14.92
450 17.72	193.5 7.62	209.5 8.25	219 8.62	385.5 15.18	401.5 15.81	411 16.18
500 19.69	225.5 8.88	241.5 9.51	251 9.88	449.5 17.70	465.5 18.33	475 18.70
550 21.65	257.5 10.14	273.5 10.77	283 11.14	481.5 18.96	497.5 19.59	507 19.96
600 23.62	289.5 11.40	305.5 12.03	315 12.40	545.5 21.48	561.5 22.11	571 22.48

Mounting screws

For the listed loading forces F_S to be absorbed reliably in the surrounding structure, all available through holes of the outer and inner slide having a \varnothing of 4.5 mm must be used. Alternatively, the outer slide has holes with a \varnothing of 6.3 mm for metric screws. The slotted holes, \varnothing 4.5 x 4.8 mm, are also used for mounting and facilitate adjustment. Failure to use mounting screws reduces the specified load capacity accordingly. The following screws can be used for mounting:

Designation - Standard		Outer slide	Inner slide
Socket button head screw	ISO 7380	M 4	M 4
Phillips pan head screw	ISO 7045	M 4	M 4
Phillips pan head self-tapping screw	ISO 7049	ST 3.9 / 4.2	ST 3.9 / 4.2

Rubber stop, locking device in retracted position

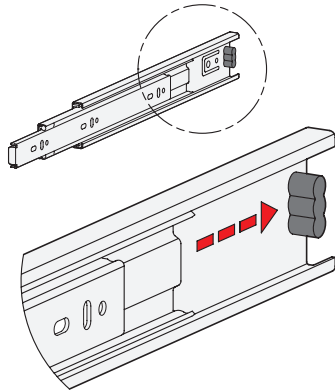

The rubber stops dampen the impact of the slide in the two end positions. This feature minimizes noise development and increases the service life. Attached to the slides in a partially concealed, partially visible manner, the stops meet each of the requirements in regards to shape, material, and hardness.

In the retracted end position, the rubber stop additionally takes on a locking function, which is noticeable through a slight resistance on opening and closing.

If larger static or dynamic loads occur in the direction of extension, they should be absorbed by additional stop elements.

Detach function

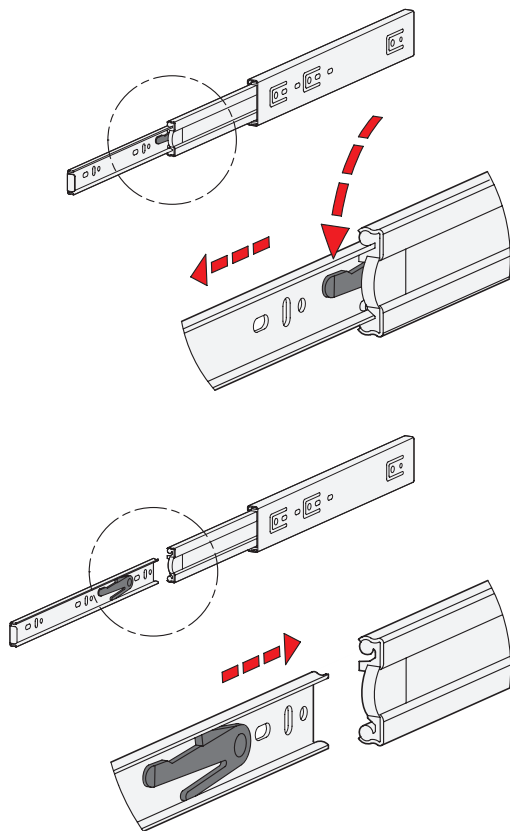

The detach function allows the extension to be completely separated from one another in the area of the middle and inner slide. This feature not only facilitates mounting, it also allows the extension to be quickly removed, for example when frequent maintenance work is performed on the components located behind.

The telescopic slide can be quickly and easily detached in the extended position through activation of the release lever, allowing the inner slide to be removed from the front.

For re-attaching the slides, the ball cages need to be moved to the extended end position. Then the inner slide is inserted to the retracted end position where it locks into place automatically.

The protected arrangement of the release mechanism prevents accidental detachment of the slide.

3.1
3.2
3.3
3.4
3.5
3.6
3.7
3.8
3.9
3.10

